

Instruction Guide

Tie Rod Sleeves



Speedtech
PERFORMANCE

CHASSIS - SUSPENSION - PRO TOURING - AUTOCROSS - DRAG RACING - CUSTOM BUILDS

435.628.4300 SPEEDTECHPERFORMANCE.COM    

4160 S. RIVER RD, ST. GEORGE, UT 84790



Figure 1: 1967 Camaro features our road assault kit, torque arm, and components [photo by Camaro Family]

Congratulations on the purchase of your new SpeedtechPerformance tie rod sleeves. Use only approved and appropriately rated jack and jack stands, and be sure to take all safety precautions required to complete the job safely and correctly. If you have uncertainties, seek the assistance of a highly qualified workshop to assist you.

Read and understand all instructions thoroughly before you begin. Your main assembly and set up of your new tie rod sleeves can be done in a home garage with hand tools.

Speedtech enjoys seeing the progress our customers are making as they work through their builds. Join the group, [Team Speedtech](#), on Facebook and share your pictures and your story.

Speedtech Performance sends you best wishes for your project!

TABLE OF CONTENTS

1.0	GENERAL INFORMATION.....	4
1.1	THIS GUIDE.....	4
1.2	OVERVIEW.....	4
1.3	TOOLS.....	4
2.0	CHECK IN PARTS AND HARDWARE.....	4
2.1	CHECKING IN THE ORDER.....	4
2.2	CHECK IN TABLE.....	5
3.0	GETTING STARTED.....	5
3.1	LEVELING AND SUPPORT.....	5
4.0	INSTALLATION.....	5
4.1	JAM NUTS.....	5
4.2	SLEEVE.....	5
4.3	ALIGNMENT.....	6
4.4	ALIGNMENT SPECS.....	7
5.0	CONGRATULATIONS.....	8

1.0 GENERAL INFORMATION

[Back to Table of Contents](#)

1.1 THIS GUIDE

Thank you for purchasing your new Speedtech Performance tie rod sleeves. Read through all instructions thoroughly before beginning and take all safety precautions required to do the job carefully and correctly.

The following instructions are intended for professional installers and are guidelines only. Speedtech Performance assumes no responsibility for the installation of any of its products installed by others. All products are intended to be installed by qualified professionals.

1.2 OVERVIEW

These instructions outline the Speedtech Performance tie rod sleeves. Photos in the instruction process may vary slightly from your exact operation. For example, in this guide we have only used pictures of the tie rod sleeves for first gen Camaro. Your application may have a slightly different shape; the part is functionally the same and is installed in the same manner described

NOTE: Some replacement tie rods will require trimming to allow for correct toe adjustment.

1.3 TOOLS

Installation of the Speedtech Performance tie rod sleeves can be done on the floor with simple hand tools.

Additional things to have before you start:

- Socket / Wrench
- Floor Stands
- Floor Jack

2.0 CHECK IN PARTS AND HARDWARE

[Back to Table of Contents](#)

2.1 CHECKING IN THE ORDER

Check in your order as soon as possible. To check in the order, Speedtech has provided a table which can be used as a check list, as displayed in figure 2. All bolts and nuts are NF unless otherwise noted. Hardware comes in several boxes. If you discover anything missing from your order, call your authorized dealer as soon as possible.

2.2 CHECK IN TABLE

X	#	Description	Size
	2	Billet Tie Rod Sleeves	
	2	Right Hand Thread Jam Nut	
	2	Left Hand Thread Jam Nut	

Figure 2: Check in table with amounts and descriptions

3.0 GETTING STARTED

[Back to Table of Contents](#)

3.1 LEVELING AND SUPPORT

Always ensure the car is safely supported. This can be done on the ground with the suspension installed, or on a lift/jack stands. Keep the car level and square when in the building process.

4.0 INSTALLATION

[Back to Table of Contents](#)

4.1 JAM NUTS

Thread a jam nut several threads onto both the inner and outer tie rod ends.

NOTE: One is left hand thread – one is right hand thread.

4.2 SLEEVE

Apply anti-seize to the threads on both ends of the adjuster sleeve.

Thread the adjuster sleeve a couple of threads onto inner tie rod. Thread the outer joint the same number of threads into the other end of the adjuster.

Holding the outer joint steady, use the other hand to rotate the adjuster sleeve so that it simultaneously tightens down both sides. Do this an equal amount of times until it lines up with the spindle steering arm and the wheel pointing straight forward.

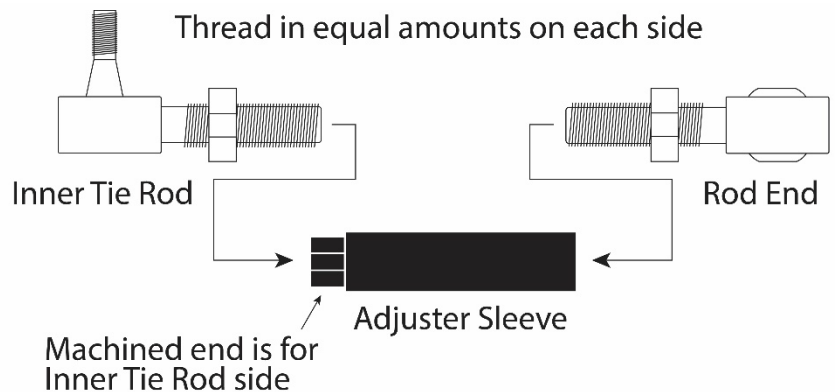

Figure 3: Threading tie rods

4.3 ALIGNMENT

Using a center point on the frame as a reference, align the middle of the center link to the center of the vehicle so both inner tie rod ends are the same distance from the center of the car. When doing this check that the steering wheel is straight.

Now with the suspension at ride height and the wheels and tires bolted in place, adjust each side's toe setting by turning the adjuster sleeves equally either forward or backward until the tires are facing forward.

You can get the toe setting fairly close by adjusting the suspension until the distance between the points on the front side of each tire is equal to the distance between the points on the rear side of each tire, see (X) in the diagram below.

Adjust as needed until both front and rear measurements are near the same. When finished, snug all four jam nuts finger tight. This will be close enough to drive the car onto a trailer to take to a competent alignment shop.

WARNING: Do not street drive the car in this condition other than to load it on a trailer.

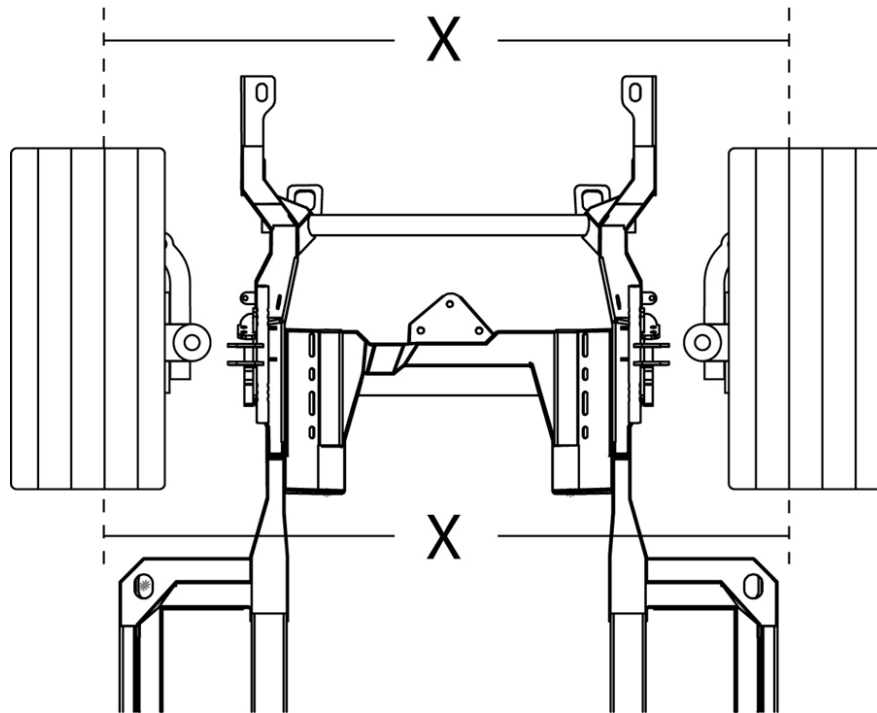

Figure 4: Alignment

4.4 ALIGNMENT SPECS

Bring the car to a reputable alignment shop that is familiar with performance alignment settings and how they all correlate with each other. Check that the shop knows the following but is not limited to the caster, camber gain, toe settings for specific types of driving/racing, bump steer adjustment, etc.

When the alignment is finalized the alignment technician will then tighten the tie rod adjuster jam nuts.

Daily Driving, Street Performance Specifications

Driver Side	Passenger Side
4 Degrees positive Caster	4 ½ Degrees positive Caster
0 to ½ Degree negative Camber	0 to ½ Degree negative Camber
3/ 32 Total Toe-in	3/ 32 Total Toe-in

Aggressive Track Alignment Specifications

Driver Side	Passenger Side
5 ½ Degrees positive Caster	6 Degrees positive Caster
½ to 1 Degree negative Camber	½ to 1 Degree negative Camber
3/ 32 Total Toe-in	3/ 32 Total Toe-in

Original Alignment Specifications

**For reference purposes only. Do not use these specs.

Driver Side	Passenger Side
½ Degree positive Caster	½ Degree positive Caster
¼ to ½ Degree negative Camber	¼ to ½ Degree negative Camber
1/8 Total Toe-in	1/8 Total Toe-in

Figure 5: Alignment specifications

IMPORTANT: Recheck the torque on all fasteners after 100 miles.

5.0 CONGRATULATIONS

[Back to Table of Contents](#)

Congratulations on completing your project! We know you will get many years of enjoyment from your project. Please join the group, [Team Speedtech](#), on Facebook. Team Speedtech is a community of customers, dealers, and factory employers that have a passion for pro touring muscle cars and are using Speedtech Performance products. You can ask questions and get advice from the group members and share your experience. Everyone enjoys seeing the videos and pictures during the progress of your project and Speedtech encourages you to share them!

Thank you for choosing Speedtech Performance and entrusting us with your tie rod sleeves for your custom muscle car.

Speedtech Performance, LLC
4160 S. River Rd.
St George UT, 84770
(435) 628-4300