

Instruction Guide

61" Independent Rear Suspension



Speedtech
PERFORMANCE

CHASSIS - SUSPENSION - PRO TOURING - AUTOCROSS - DRAG RACING - CUSTOM BUILDS

435.628.4300 SPEEDTECHPERFORMANCE.COM    

4160 S. RIVER RD, ST. GEORGE, UT 84790



Figure 1: 454SS OBS

Congratulations on the purchase of your new Speedtech Performance Independent Rear Suspension (IRS). Use only approved and appropriately rated jack and jack stands, and be sure to take all safety precautions required to complete the job safely and correctly. If you have uncertainties, seek the assistance of a highly qualified workshop to assist you.

Read and understand all instructions thoroughly before you begin. Your main assembly and set up of your new IRS can be done in a home garage with hand tools.

Speedtech enjoys seeing the progress our customers are making as they work through their builds. Join the group, [Team Speedtech](#), on Facebook and share your pictures and your story.

Speedtech Performance sends you best wishes for your project!

TABLE OF CONTENTS

1.0 GENERAL INFORMATION.....	4
1.1 THIS GUIDE	4
1.2 OVERVIEW	4
1.3 TOOLS	4
2.0 CHECK IN PARTS AND HARDWARE.....	4
2.1 CHECKING IN THE ORDER.....	4
2.2 CHECK IN TABLES	5
2.3 HIGH MOUNT OVERVIEW	8
3.0 GETTING STARTED / INSTALLATION	10
3.1 REAR DIFFERENTIAL INSTALL	10
3.2 PINION SUPPORT	11
3.3 DIFFERENTIAL BRACKET	12
3.4 LOWER CONTROL ARMS	12
3.5 ROCKER BASE SPACER PLATE	13
3.5.1 SHOCK ROCKER ASSEMBLY – FOR HIGH MOUNT	13
3.6 SHOCK INSTALLATION.....	14
3.7 PUSH ROD.....	15
3.8 SPINDLE ISNTALLATION	16
3.9 UPPER CONTROL ARM	17
3.10 CV AXLE INSTALLATION	18
3.11 SWAY BAR ASSEMBLY	19
3.12 TOE BAR INSTALLATION	20
4.0 TORQUE/ALIGNMENT	21
5.0 WARRANTY.....	22
6.0 CONGRATULATIONS.....	24

1.0 GENERAL INFORMATION

[Back to Table of Contents](#)

1.1 THIS GUIDE

Thank you for purchasing your new Speedtech Performance Independent Rear Suspension System. The following instructions are intended for professional installers and are guidelines only. Speedtech Performance assumes no responsibility for the installation of any of its products. All must be installed by qualified professionals only.

NOTE: This kit requires previously install component design specifically for your project. The subframe or chassis are unique to each vehicle. These kits have their own set of instructions for proper fitment. Even though each vehicle is unique, the general concepts and specific specs remain the same across the vehicle line for installing the Independent Rear Suspension assembly.

1.2 OVERVIEW

These instructions outline the Independent Rear Suspension System that will be installed with the Speedtech Performance chassis or subframe. Photos in the instruction process may vary slightly from your exact operation.

1.3 TOOLS

Installation of the Speedtech Performance Independent Rear Suspension System can be done on the floor with simple hand tools.

Additional things to have before you start:

- Wrench
- Socket Set
- Floor Jack
- Jack Stands
- Red Loctite

2.0 CHECK IN PARTS AND HARDWARE

[Back to Table of Contents](#)

2.1 CHECKING IN THE ORDER

Check in your order as soon as possible. To check in the order, Speedtech has provided tables which can be used as check lists, as displayed in figure 2. All bolts and nuts are NF unless otherwise noted. Hardware comes in several boxes. If you discover anything missing from your order, call your authorized dealer as soon as possible.

2.2 CHECK IN TABLES

Upper Control Arm

	2	Upper Control Arms Assembled: Passenger and Driver	
	2	Upper Control Arm Ball Joint (Assembled)	
	2	Upper Control Arm Ball Joint Nut (Assembled)	Aluminum Cap
	8	Control Arm Bushings (Assembled)	Delrin Plastic
	4	Grease Zerks (Assembled)	
	8	Control Arm Bushing Hats (Assembled)	Aluminum Disk
	4	Control Arm Pin Mounts Male (Assembled)	
	4	Control Arm Pin Mounts Female (Assembled)	
	8	Control Arm Mount Standoffs (In Hardware)	Aluminum Square
	2	Ball Joint Spacers (In Hardware)	0.30" Thick
	2	Ball Joint Castle Nut w/ Cotter Pin	
	8	Control Arm Mounting Bolts (In Hardware)	1/2" x 2-1/4" HHS
	8	Control Arm Mounting Washers (In Hardware)	1/2" I.D.

Lower Control Arm

	2	Lower Control Arms Assembled: Passenger and Driver	
	2	Lower Control Arm Ball Joint (Assembled)	
	8	Control Arm Bushings (Assembled)	Delrin Plastic
	4	Grease Zerks (Assembled)	
	8	Control Arm Bushing Hats (Assembled)	Aluminum Disk
	4	Control Arm Pin Mounts Male (Assembled)	
	4	Control Arm Pin Mounts Female (Assembled)	
	8	Control Arm Mount Standoffs (In Hardware)	Aluminum Square
	2	Ball Joint Castle Nut w/ Cotter Pin	
	6	Control Arm Mounting Bolts (In Hardware)	1/2" x 2-1/4" HHS
	8	Control Arm Mounting Washers (In Hardware)	1/2" I.D.
	2	Control Arm Mounting Nylocks (In Hardware)	1/2
	2	Control Arm	
	2	Flat Washer (In Hardware)	1/2
	4	Machined Square Nuts (Rear Mount) (In Hardware)	1/2
	2	Bump Stops Nuts (In Hardware)	
	2	Bump Stops Lock Washers (In Hardware)	
	2	Bump Stops (In Hardware)	Bee Hive Shaped

Rocker Push Rod

	2	Push Rods	13-1/4" Long
	2	Rod End Left-Hand Thread	5/8 w/ 1/2" I.D. LHT
	2	Rod End Right-Hand Thread	5/8 w/ 1/2" I.D.
	2	Jam Nut Left Hand Thread	5/8 LHT
	2	Jam Nut Right Hand Thread	5/8
	4	Push Rod Shoulder Bolts	1/2 x 1-3/4" SHSS
	2	Rocker Mount Thin Nylocks	3/8 NC
	2	Lower Control Arm Mount Nylocks	3/8 NC
	2	Lower Control Arm Mount Washers	3/8" I.D.

Toe Rod

2	Steering Tie Rods Tube	13-1/4" Long
2	Rod End Left-Hand Thread	5/8 Standard LHT
2	Rod End Right-Hand Thread	5/8 Standard
2	Jam Nut Left Hand Thread	5/8 LHT
2	Jam Nut Right Hand Thread	5/8
2	Frame Mount Shoulder Bolts	5/8 x 1-1/4" SHSS
2	Frame Mount Washers	1/2" I.D.
2	Frame Mount Nylock Nuts	1/2 NC
2	Steering Arm Spacer Tall	0.60" Cone Shape
2	Steering Arm Spacer Short	1/4" Hat Shape
2	Steering Arm Nylock Nuts	1/2
2	Steering Arm Mount Shoulder Bolt	5/8 x 2-1/2" SHSS

Rear Sway-bar Link

1	Spline Sway Bar (Not In Hardware Kit)	31"
2	Sway Bar Bushings	Delrin Plastic
2	Grease Zerks	
2	Adjustable Sway Bar Arm	
2	Sway Bar Arm Pinch Bolts	1/4 x 2" HHS
2	Sway Bar Arm Pinch Nylock Nuts	1/4
2	Sway Bar Arm Link Tube	2-1/2" Long
2	Rod End Left-Hand Thread	1/2 Standard LHT
2	Rod End Right-Hand Thread	1/2 Tall
2	Jam Nut Left Hand Thread	1/2 LHT
2	Jam Nut Right Hand Thread	1/2
2	Sway Bar Arm Mount Shoulder Bolts	1/2" x 1-1/4" SHSS
2	Lower Control Arm Mount Shoulder Bolts	1/2" x 1-3/4" SHSS
2	Sway Bar Arm Mount Spacer	5/32" Thick
4	Shoulder Bolt Nylock Nuts	3/8
4	Shoulder Bolt Washers	3/8" I.D.

Frame Hardware

1	Pinion Mount 61" Steel	Welded Piece
5	Pinion Bolts	3/8 x 1 3/4" NC HHS
4	Pinion Mount Frame Bolts	7/16 x 1" NC HHS
9	Pinion Washers	3/8" I.D.
2	Ford 9in Center Lower Mount Bolts	3/4 x 5 1/2" HHS
4	Ford 9in Center Top Mount Bolts	5/8 x 2" SHCS
4	Ford 9in Center Top Mount Spacers	Aluminum 1/2" Thick
2	Differential Mounting Brackets	Bent Metal Bracket
4	Differential Mounting Bolts	1/2 x 1 1/2
8	Differential Mounting Flat Washers	1/2"
4	Differential Mounting Nuts	1/2"

One of the following kits will be included.

Traditional Shock Mount

	2	Coil Over Mounting Shoulder Bolts – Upper	1/2" x 3/4" SHSS
	2	Coil Over Mounting Shoulder Bolts – Lower	1/2" x 3" SHSS
	2	Shock Spacer Bushing	
	4	Washer	3/8"
	4	Nylock Nuts	3/8" -24

Suspension Rocker High Mount

	2	Rockers (Assembled)	
	4	Rocker Bearings (Assembled)	
	2	Bearing Sleeves (Assembled)	
	4	Bearing Bushings (Assembled)	
	2	Rocker Frame Mounts: Front and Back	
	2	Rocker Pivot Mount Shoulder Bolts	5/8" x 2-1/2" SHSS
	2	Rocker Mount Coil-over Shoulder Bolts	1/2" x 2-1/2" SHSS
	2	Coil-over to Rocker Shoulder Bolts	1/2" x 1-3/4" SHSS
	2	Coil-over to Rocker Thin Nylock Nuts	3/8 NC
	6	Rocker Mount Bolts	1/2 x 1-3/4" SHCS
	2	Rocker Spacer Plate	
	2	Rocker Mount Bolts	1/2 x 1 3/4" SHCS

Figure 2: Check in tables with amounts, descriptions, and sizes

2.3 HIGH MOUNT OVERVIEW

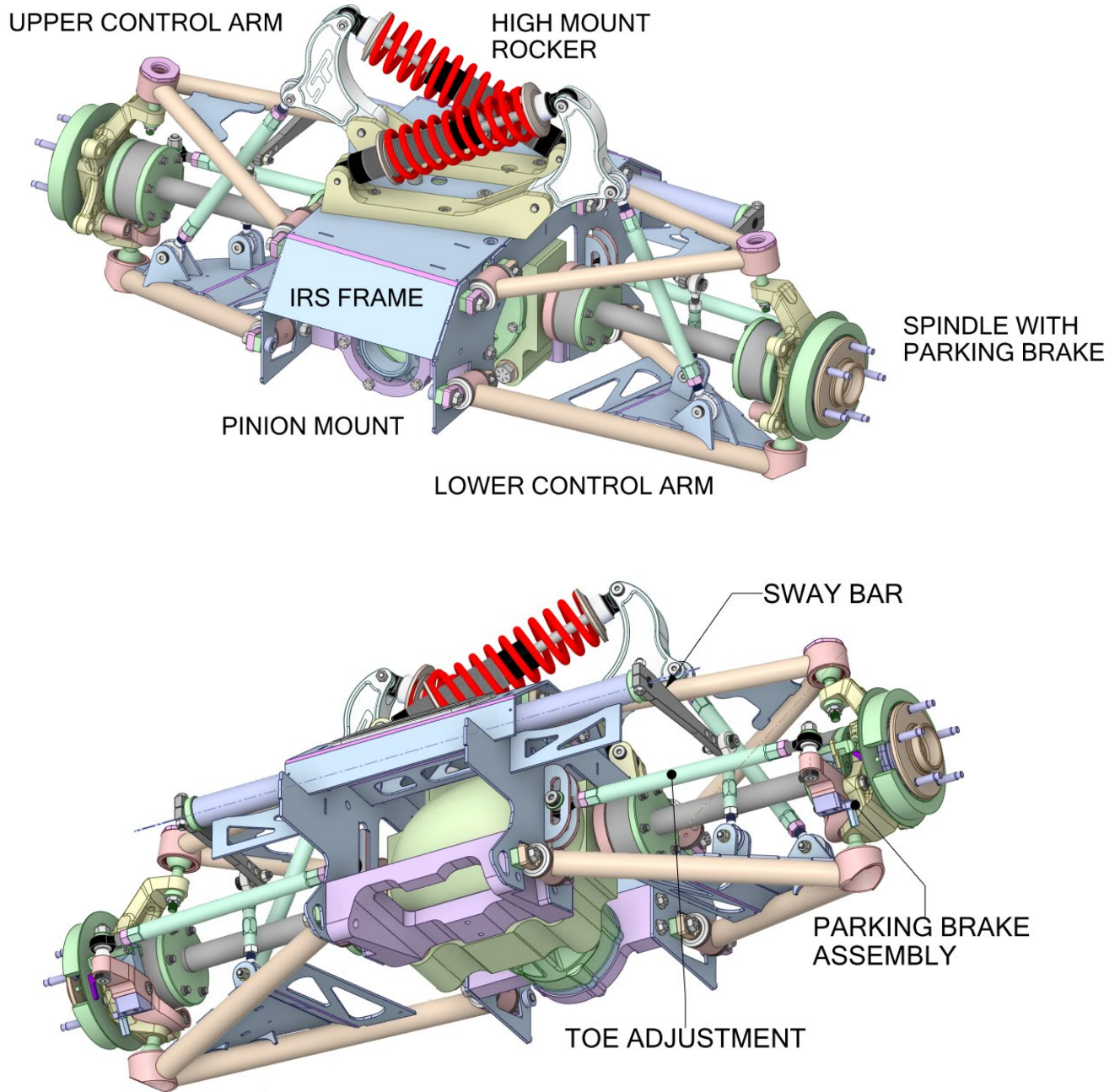

Figure 3: Two modes of the high mount overview

TRADITIONAL SHOCK MOUNT OVERVIEW

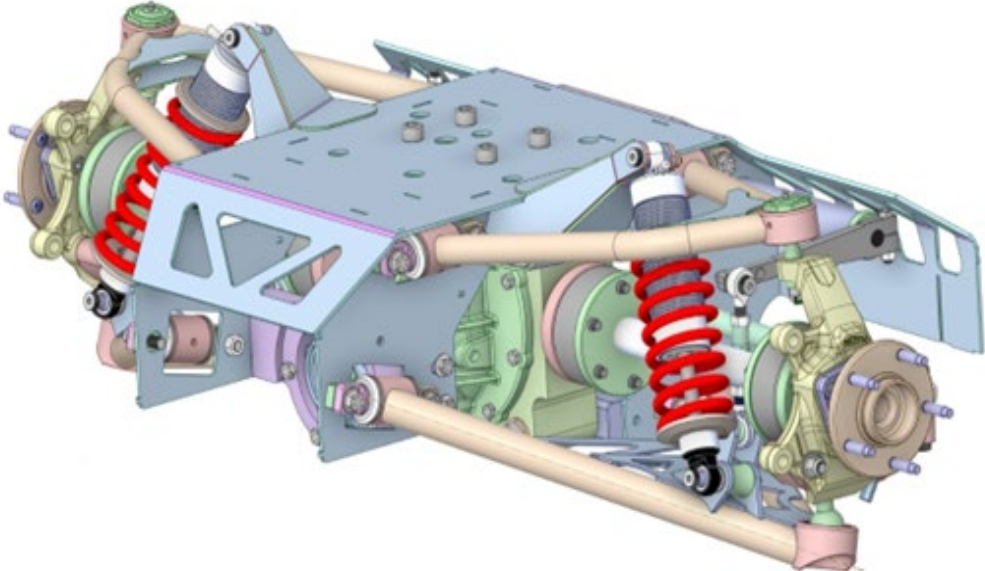

Figure 4: One model of traditional shock mount overview

3.0 GETTING STARTED / INSTALLATION

[Back to Table of Contents](#)

3.1 REAR DIFFERENTIAL INSTALL

NOTE: There is an optional step in this first part that makes installation of the differential much easier. Make two studs that fit into the top of the differential (5/8-18). Hand-turn them in the housing on opposite corners so they are sticking out about two inches. Place two Delrin spacers on the studs and prepare to lift it into place.

- Prepare the differential to lift into place. Follow Dutchman's instructions to assemble. Speedtech recommends using a floor jack to assist in lifting.
- Lift the differential into the frame. Leave about an inch gap on the top.
- Adjust the differential so that the four holes on top line up with the holes in the frame.
- Place the Delrin spacers one at a time on the top of the housing, then thread the 5/8x2 SHCS from the top, down into the spacers and into the holes. Repeat this for the other three holes.
- Take extra care and slowly and evenly tighten the bolts. Make sure you do not cross thread as you lift the differential into place.
- Do not fully tighten bolts until final assembly with the other two mounts installed.
 - On final assembly, use blue Silicone and torque to 75 ft.lb.

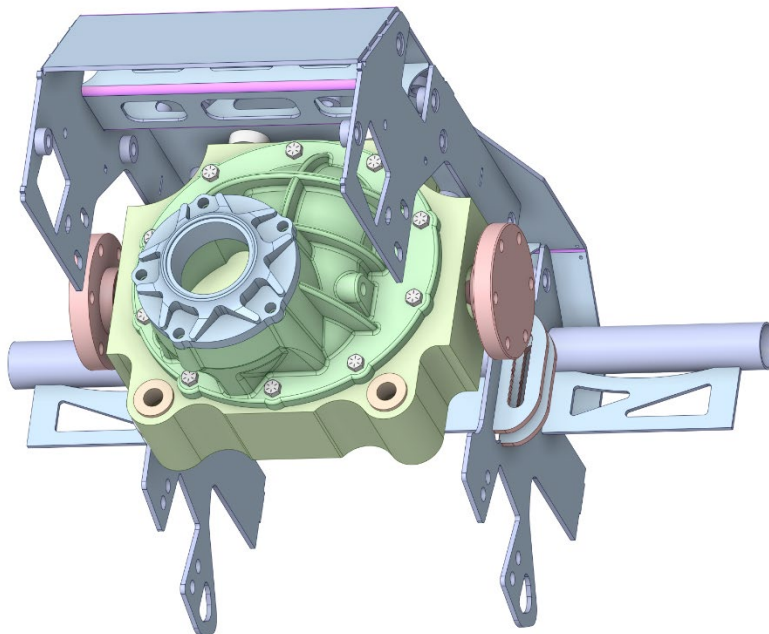
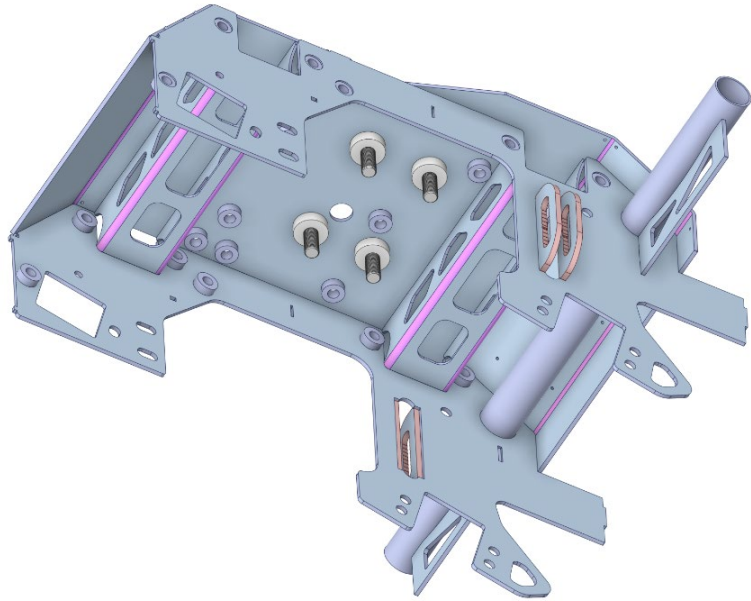

Figure 5: Two models of rear differential install

3.2 PINION SUPPORT

NOTE: The bolts cannot be fully tightened until the lower control arm is installed. There are also some critical points that line everything up; you will need to shake the housing so that the points can align. The red Loctite is more than just bolt locker in this case. It will be acting as a sealant to the open holes in the top of the casing, keeping the differential fluid inside.

- Remove the five bolts that are holding the pinion to the differential. The bolts can be discarded as they will be replaced.
- Bolt on the pinion support. There are two different styles of pinions and your applications will determine which bolts to use.
 - The standard pinion will use (5) 3/8x2-1/4 coarse thread.
 - On final assembly, use red Loctite and torque to 38 ft.lb.
 - Strange HD pinion will use (5) 7/16x2-1/2 coarse thread.
 - On final assembly, use red Loctite and torque to 52 ft.lb.
- Bolt the pinion support to the frame. Use (4) 7/6x1-1/4 with washers.
On final assembly, use red Loctite and torque to 45 ft.lb.

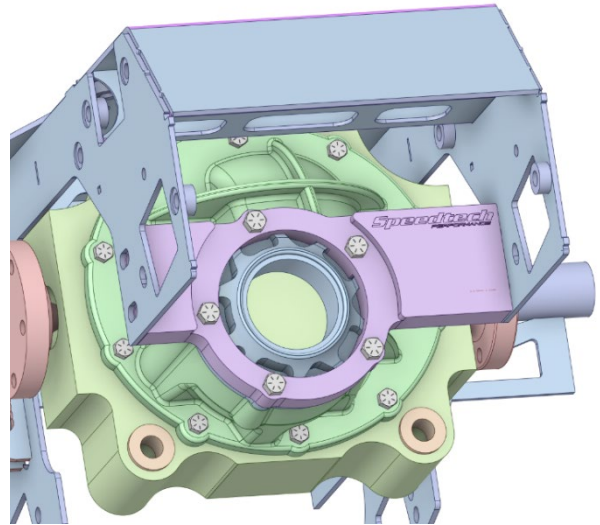
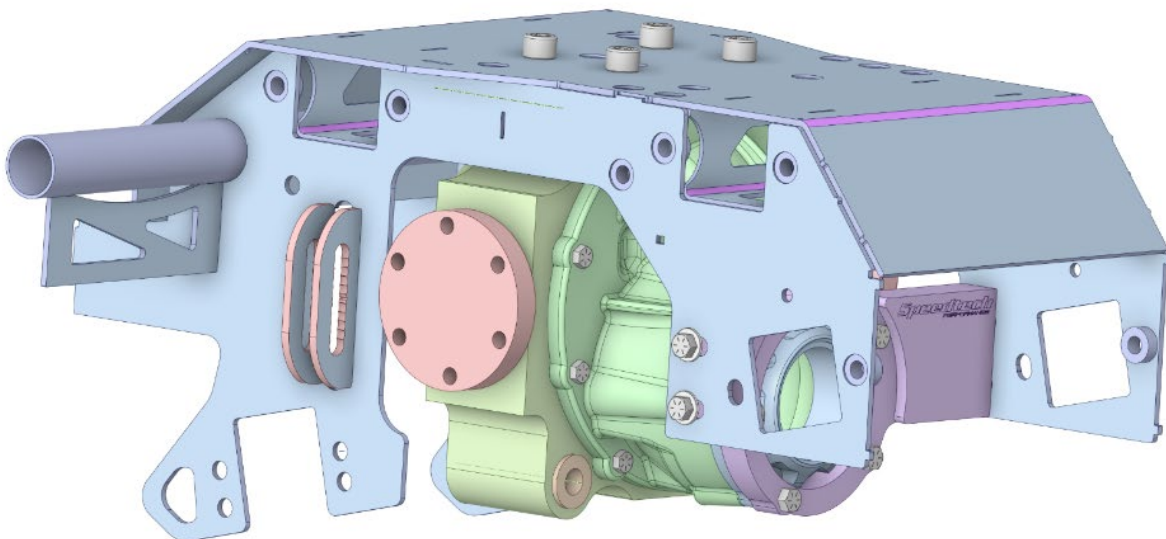

Figure 6: Two models of pinion support



3.3 DIFFERENTIAL BRACKET

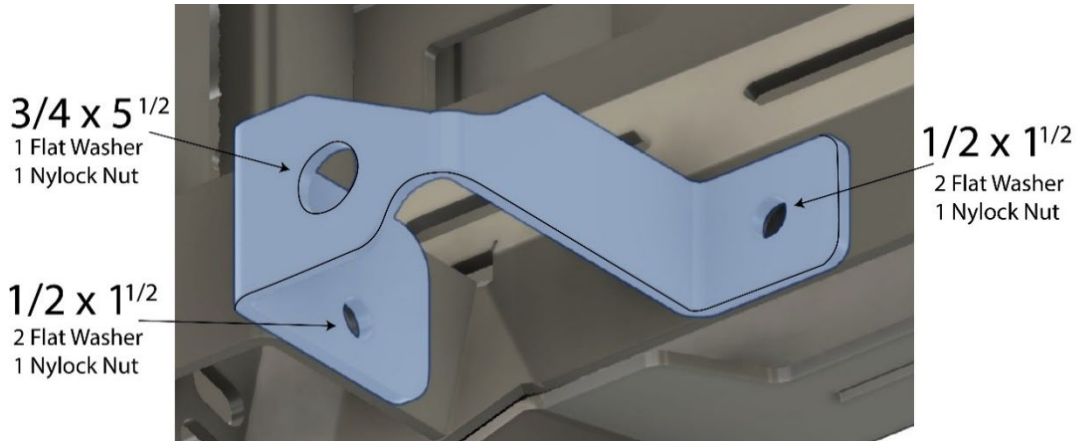

Figure 7: Differential bracket

3.4 LOWER CONTROL ARMS

NOTE: The lower control arms will come assembled with the mounting plate zip tied together. The ball joint is preinstalled; however, you will need to install the camber spacers.

- Orient the control arms.
- Prepare them for install by cutting the zip tie, placing the camber spacers, and inserting 1/2x2-1/4 bolts and washers into the pins and camber spacer. Ensure the radius edge is against the pin. The flat edge is against the pin. The flat edge goes against the chassis.

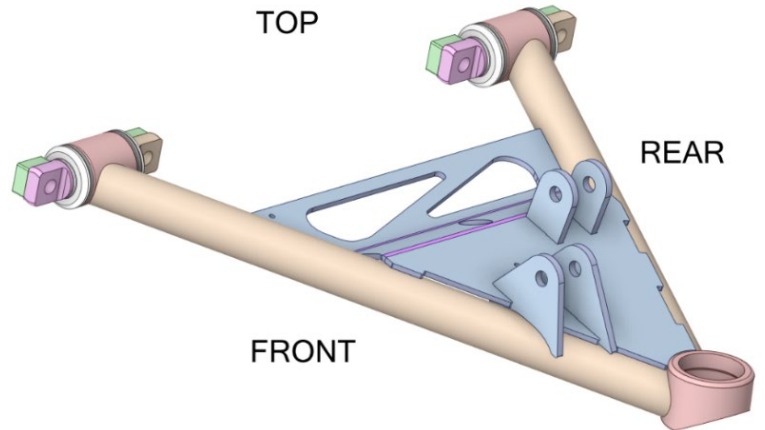
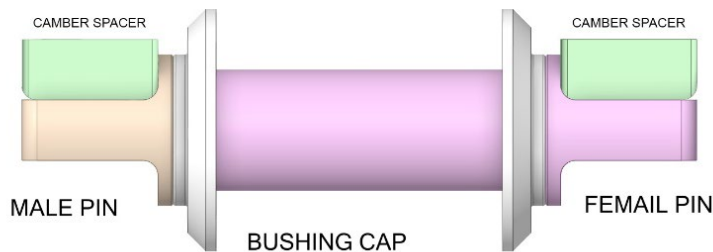

Figure 8: A model and close up of the lower control arms

- Bolt into the frame using the upper holes for street driving or the lower mount holes for road course racing.



- The rear two bolts screw into the aluminum mid plate.
 - On final assembly, use anti-seize and torque to 60 ft.lb.
- The most front bolt screws into a threaded insert in the frame.
 - On final assembly, use anti-seize and torque to 60 ft.lb.
- The second front bolt will need a washer and nylock nut on the inside of the frame.
- On final assembly, torque to 60 ft. lb.

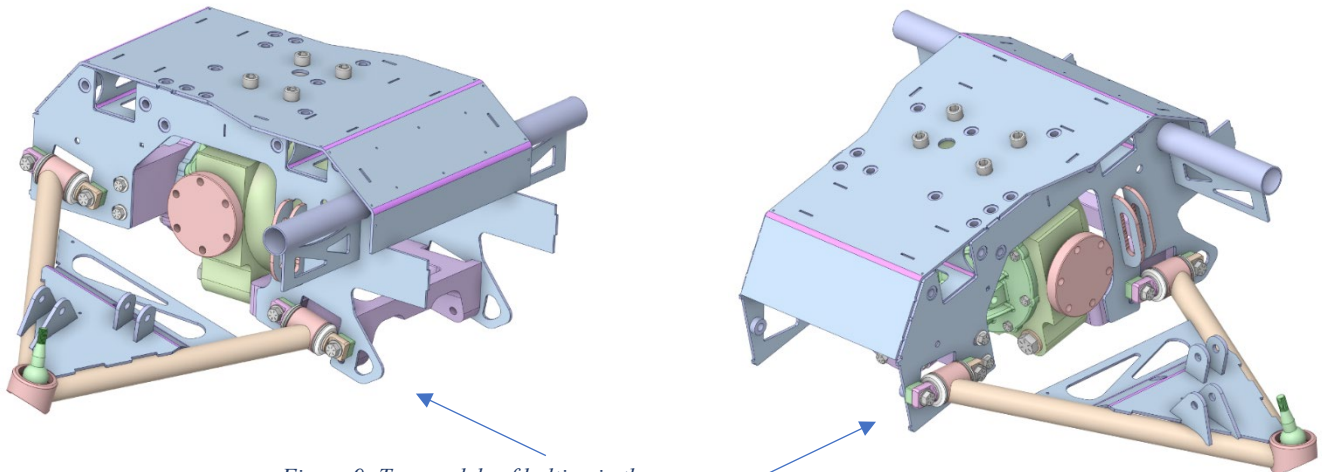
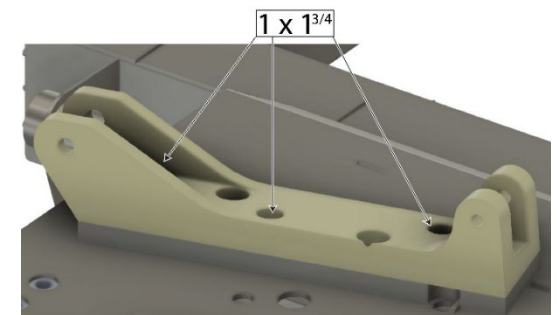
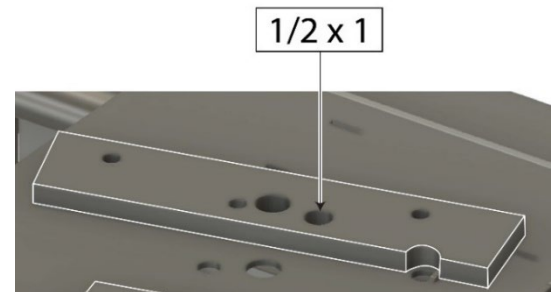

Figure 9: Two models of bolting in the arms

3.5 ROCKER BASE SPACER PLATE

NOTE: The base plate is only for a 61" wide IRS application. The two base plates are unique and have to be install in the correct places. The rear base for passenger side has two additional holes to go over the existing differential bolts.

- Identify the two rocker base plates.
- Using the 1/2 x 1 SCHS, as indicated in figure 10, attach the rear plate to the IRS housing.
 - **NOTE:** Temporarily install the two 1 3/4 bolts on each end to ensure the plate is installed straight. After torquing the center bolt, remove these for fitment on the rocker base.
 - Use red Loctite and torque to 60 ft.lb.
- Line the front base plate up with the holes in the IRS housing. You will sandwich this spacer plate fully using the rocker base.



3.5.1 SHOCK ROCKER ASSEMBLY – FOR HIGH MOUNT

NOTE: The images may look slightly different than your exact application.

NOTE: The two shock mount plates are unique and have to be installed in the correct places. The rear base for passenger side rocker has two additional holes to go over the existing differential bolts, only in a 56" application.

- Identify the two rocker bases.
- Install them onto the top of the frame using (3) 1/2x1 SHCS each.
 - On final install, use Red Loctite and torque to 60 ft.lb.

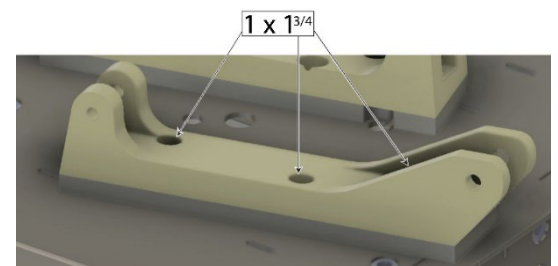

Figure 10: Three images of the rocker base spacer plate

- Locate the two rocker claws and prepare them for install. The bearings and sleeves are preinstalled, ensure that the assembly is centered.
 - Refer to the diagram and double check that the rockers are assembled correctly.
- Install the rockers into the bases. The long end will point up and in, the short end will point out and down. Refer to the picture for orientation.
 - Make sure that the total bearing stack is intact.
 - Use the 5/8 x 2-1/2 shoulder bolt. Threading it through the whole assembly, seating it into the counterbored base.
 - One final assembly, use anti-seize and torque to 40 ft.lb.

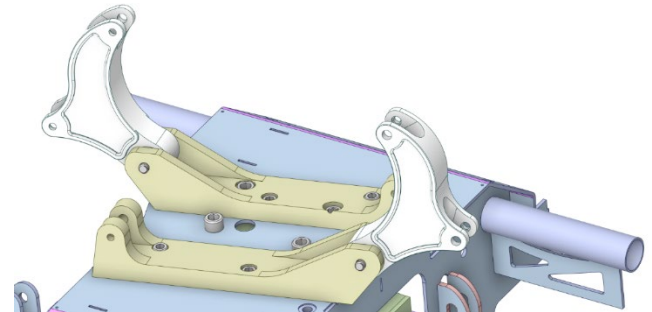
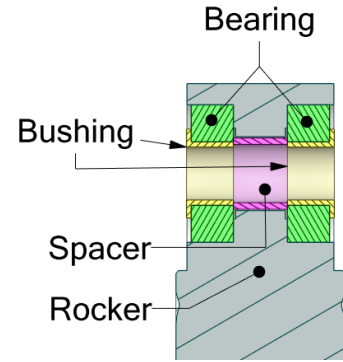

Figure 11: Two models for the high mount shock rocker assembly

3.6 SHOCK INSTALLATION

NOTE: Depending on where you are in your build, it may be an advantage to install shock mock ups in place of the actual shocks. For intended ride height; high mount shock length is 15-5/8", low pro shock length is 15-3/8in. The following instructions are intended for final shock installation.

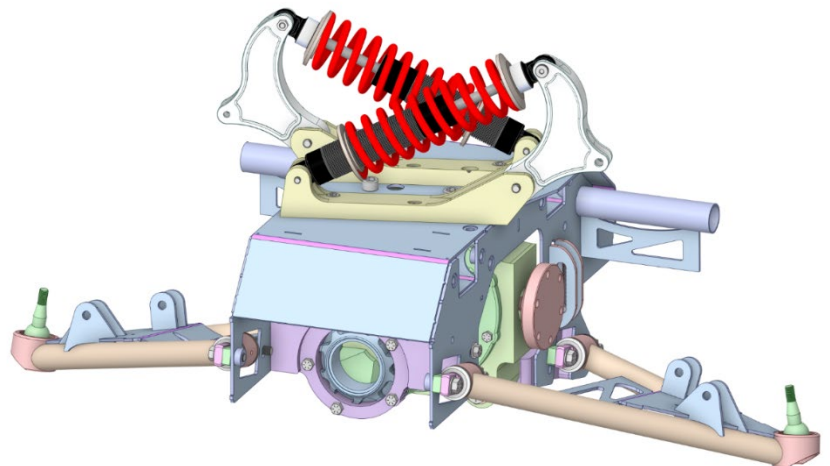

Figure 12: High mount shock install

- HIGH MOUNT SHOCK INSTALL:
 - Bolt the shock body into the base using the 1/2x2-1/2 shoulder bolt.
 - Make sure the shoulder is seated properly into the counterbored base.
 - On final assembly torque to 20 ft.lb. Then install the jam nut and torque it to 20 ft.lb.
 - Bolt the shock spring into the rocker using the 1/2x1-3/4 shoulder bolt.
 - Snug up the shoulder bolt into the threaded rocker, taking care not to strip the thread out.
 - Bolt on the 3/8 thin nylock jam nut. Torque to 20 ft.lb on final assembly.
- TRADITIONAL MOUNT SHOCK INSTALL:
 - Bolt the shock body into the upper frame using 1/2x1-3/4 shoulder bolt.

- TRADITIONAL MOUNT SHOCK INSTALL

- Bolt the shock body into the upper frame using 1/2x1-3/4 shoulder bolt.
- Tighten using a 3/8 nylock jam nut and washers.
 - On final assembly, torque to 20 ft.lb.
- Use the shock spacer bushing between the mounting tabs
- Bolt the shock body into the lower position using 1/2x3 shoulder bolt.
- Tighten using a 3/8 nylock jam nut and washers.

On final assembly, torque to 20 ft.lb.

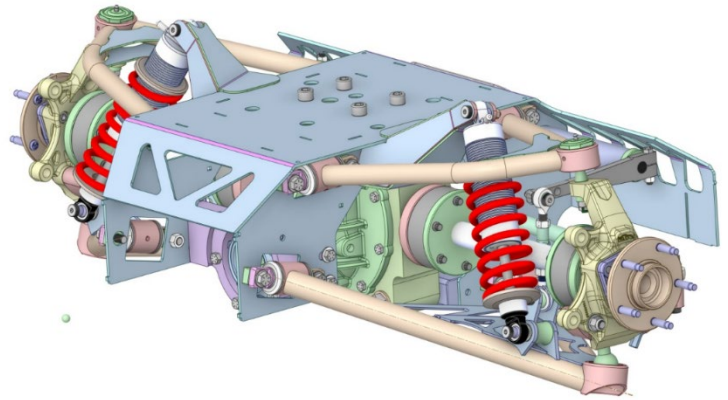

Figure 13: Traditional mount shock install

NOTE: The shoulder bolt in the frame may need some movement with the washers to fit properly. Ensure that the shoulder of the bolt is not binding on any washers that are not lined up and that the nylock nut is properly seated and is tightening the frame onto the shock rod end.

3.7 PUSH ROD

Figure 14: Push rod

- Locate and assemble the push rod; refer to figure 14.

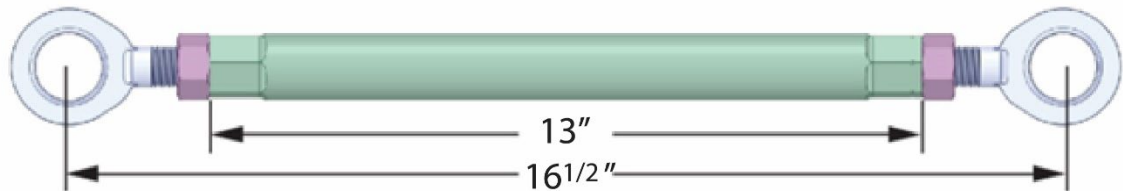

- Thread the jam nut onto the high rod ends.
- **NOTE:** One of the joints is reverse thread.
- Set the eye-to-eye width to 15" on the push rod, making sure that the thread exposed on each joint is symmetrical. Tighten the jam nut.
- Bolt one end into the rocker. Use a 1/2x1-3/4 shoulder bolt.
 - Snug up the shoulder bolt into the threaded rocker, taking care not to strip the thread out.

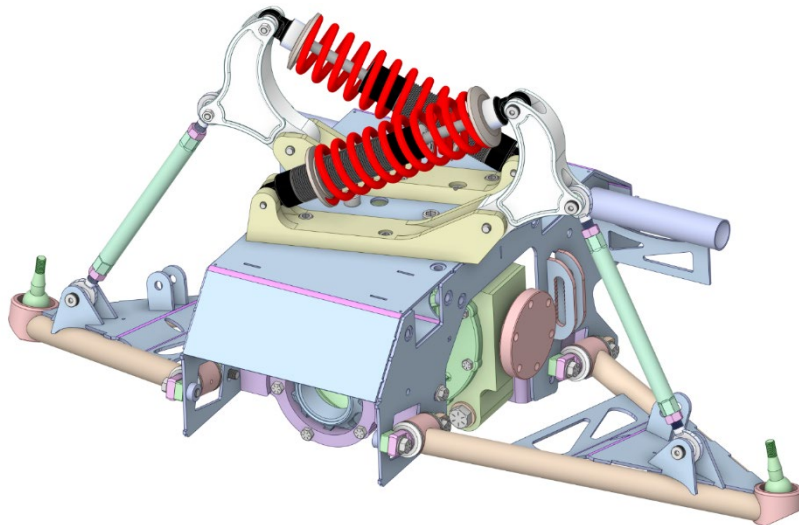

Figure 15: Adding the push rod onto the assembly

- Bolt on the 3/8 nylock jam nut. Torque to 20 ft.lb. on final assembly.
- Bolt the other end into the lower control arm. Use a ½ x 1-3/4 shoulder bolt in the forward most tabs on the arm.
 - Snug up the shoulder bolt into the threaded rocker, ensuring not to strip the thread out.
 - Bolt on the 3/8 thin nylock jam nut. Torque to 20 ft.lb. on final assembly.

3.8 SPINDLE ISNTALLATION

- Set the spindle onto the lower ball joint pin.
 - Ensure that the correct spindle is on the correct side. The brake mount will be on the forward side.
 - Tighten the castle nut onto the ball joint.
- On final assembly, torque to 60 ft.lb
- Install cotter pin.
- Install the preassembled steering arm.
 - Review the steering arm assembly with the diagram.
- Bolt steering arm onto the spindle.
 - Point the arm towards the rear.
 - Use (2) 1/2x2-1/2 SHCS.
 - Bolt on the (2) thin nylock jam nuts on the front side.

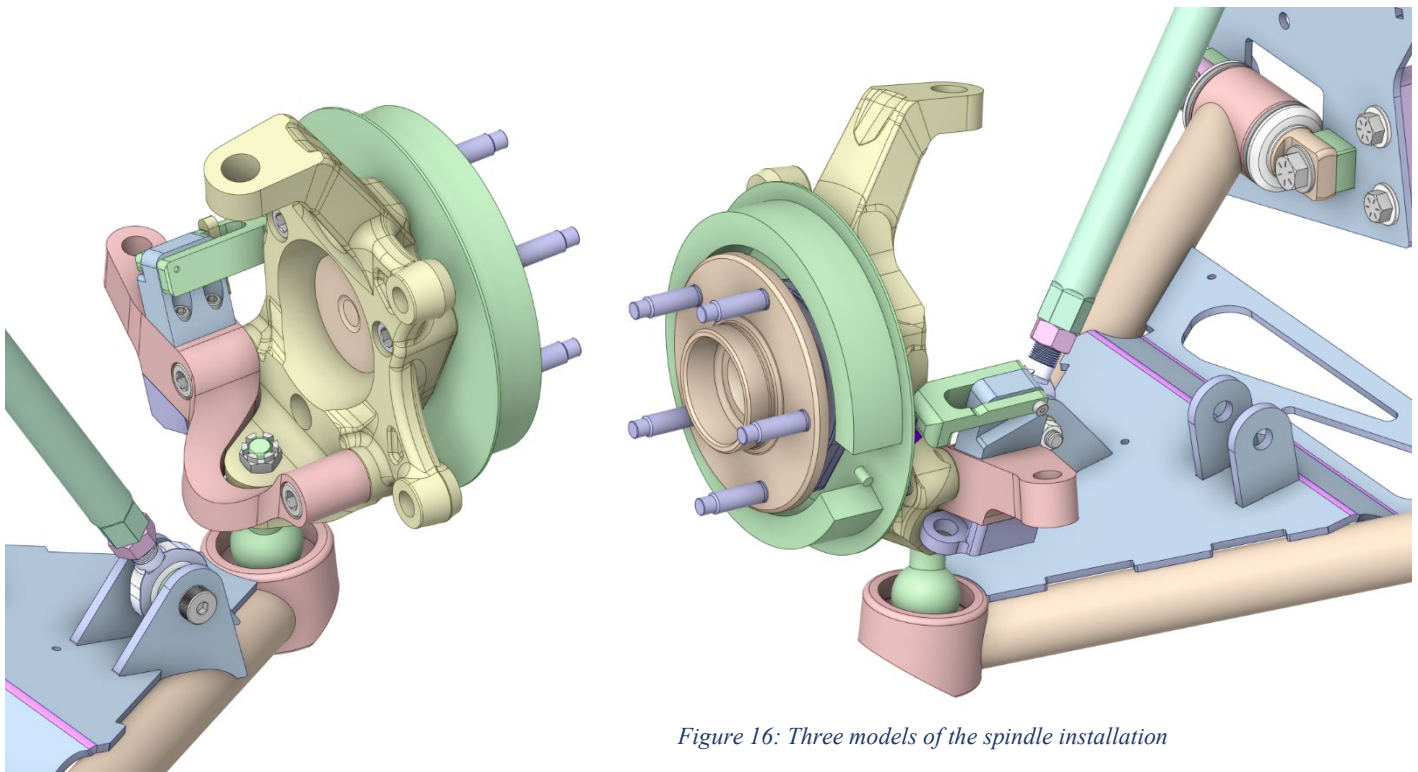
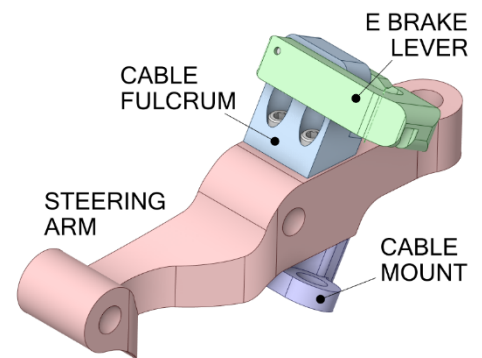

Figure 16: Three models of the spindle installation

3.9 UPPER CONTROL ARM

NOTE: The upper control arms are preassembled much the same way the lowers were assembled. Refer to the lower control arm for specifics and details on the collar/pin assembly.

- Identify the upper control arm and orient them. The bent tube in the arm is in the forward position.
- Bolt the upper control arms to the frame using (4) 1/2x1-3/4 bolts and washers on each side.
 - On final assembly, use red Loctite and torque to 60 ft.lb.

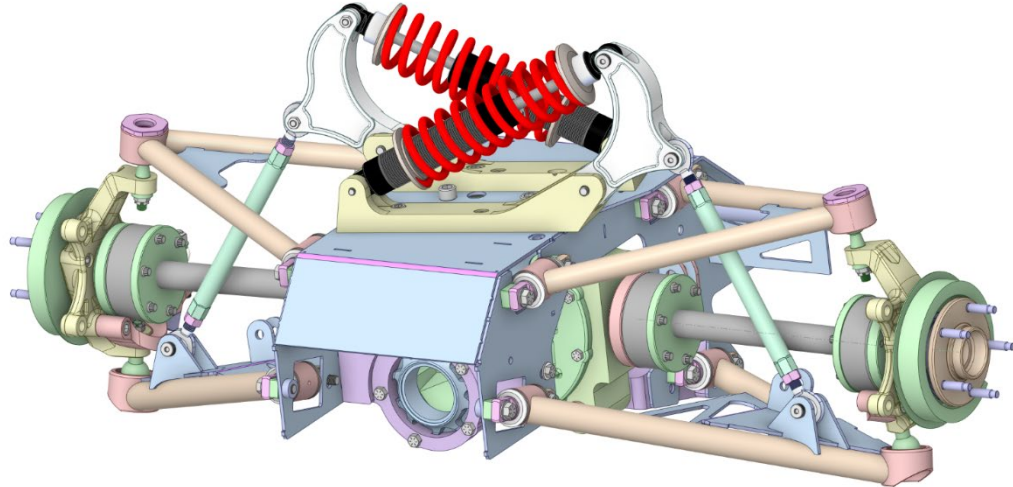

Figure 17: Upper control arm installment

NOTE: Do not attach the upper control arm to the spindle; that will be done as part of the CV axle installation, however, having the upper control arm ready will greatly assist the next step. For dry fitting, attach the upper control arm onto the spindle with the spacer.

3.10 CV AXLE INSTALLATION

NOTE: For dry fitting during the build process, this step can be skipped.

The CV joints don't need to be installed until the final assembly. Please refer to Dutchmen instruction on the specifics of their axle, warranty, stress limits, and care.

The CV joints are packed with molly grease. Take extra care working with the joints as molly grease is messy and difficult to work with.

Use the instructions to prepare the axles for install.

- Install the stub axle into the gm bearing hub on the spindle.
 - Slip in the axle into the spline drive and tighten hub nut.
- Remove one the grease plate and keep the bolts in place.
- Install the CV joint to the stub axle on the differential.
 - Torque the (6) bolts to 65 ft.lb.
- Remove the other grease plate. Keep the bolts in place.
- Bolt the CV joint to the stub axle on the spindle. Lower the upper control arm into the spindle as this will help support and stabilize the assembly.
 - Torque the (6) bolts to 65 ft.lb.
- Seat the upper control arm ball joint.
 - Tighten on the castle nut with the 0.30" aluminum spacer.
 - Torque to 45 ft.lb. Install cotter pin.
- Apply red Loctite to the hub nut, torque to 120 ft.lb.

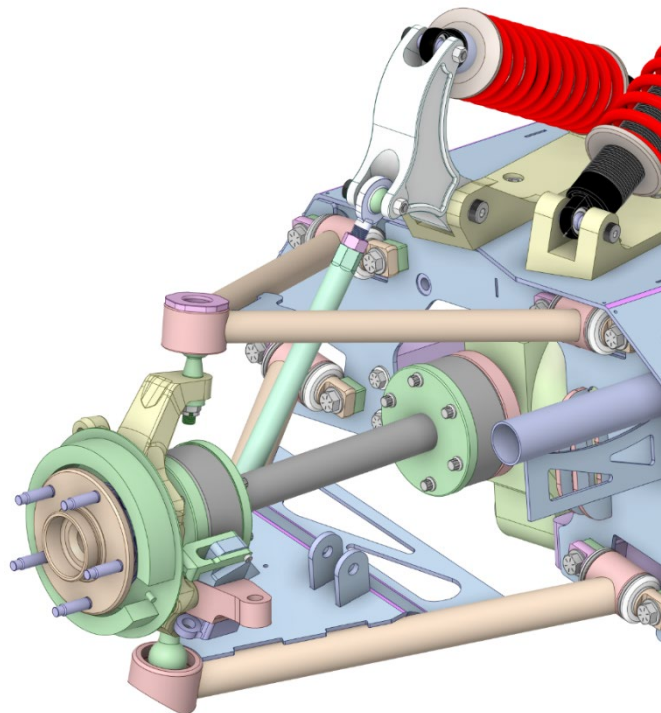
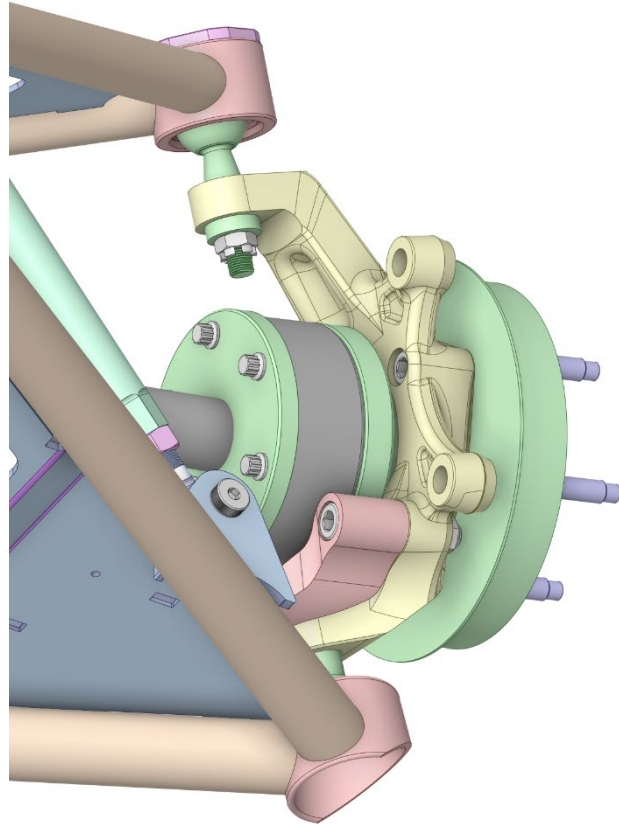

Figure 18: CV axle installment

3.11 SWAY BAR ASSEMBLY

NOTE: There are multiple mounting locations; the more forward is for street driving and the rear (closer to the bar) is for higher performance.

- Insert the splined sway bar into the tube.
- Center the sway bar in the tube by inserting the two Delrin bushings on each end.
- Clamp on the sway bar arms on each side, take extra care that they are even and parallel with each other.
 - Pinch the clamps on using the 3/8x2 bolts. Torque to 35ft.lbs.
- Prepare the sway bar link. Refer figure 19.
- Bolt the link into the sway bar arm.
 - Use a 1/2x1-1/4 shoulder bolt, spacer, 3/8 nylock, and washer.
 - Stack the spacer in-between the rod end and the sway bar arm.
- Bolt the link to the lower control arm.
 - Use a 1/2x1-3/4 shoulder bolt, nylock, and washer.

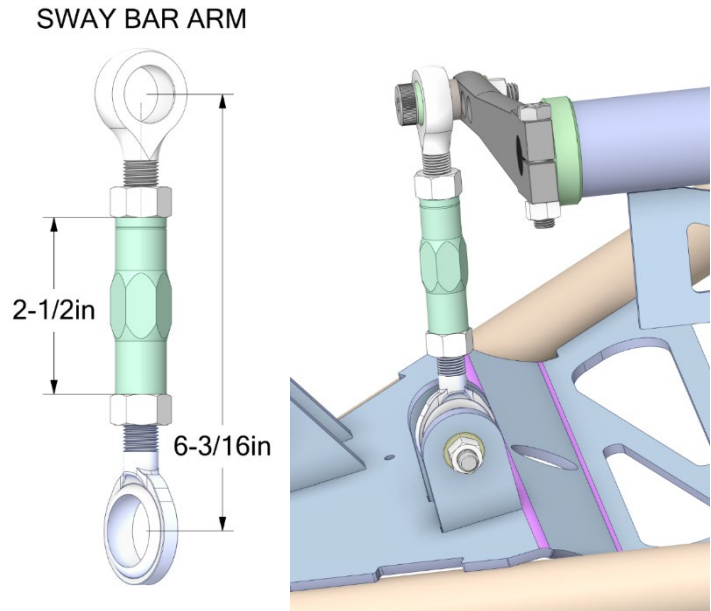

Figure 19: Two models of the sway bar assembly

Take care that the washer and nut are properly seated. Torque to 35 ft.lbs.

3.12 TOE BAR INSTALLATION

- Locate and prepare the tow steering bar; refer to figure 23.

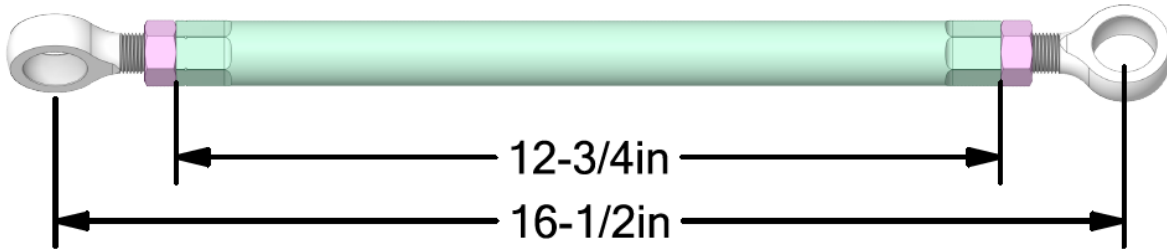
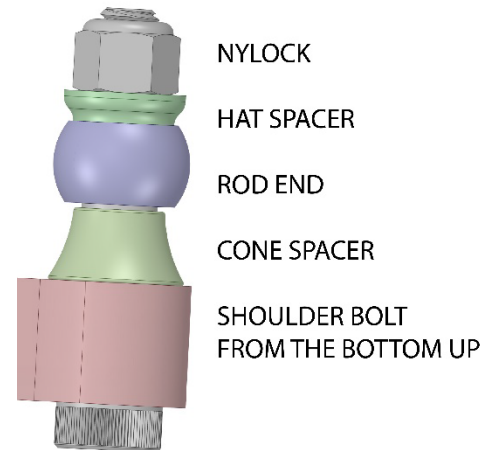

Figure 23: Tow steering bar

- Bolt one end into the frame. The initial starting point is marked.
 - Use 5/8x1-1/4 shoulder bolt, washers, and nylock nut.
 - Use the washers to ensure the proper clamping and that the bolt and nut have optimal contact.
 - On final assembly, torque to 60 ft.lb.
- Bolt the other end into the steering arm. Follow figure 24.
 - Use 5/8x2-1/2 shoulder bolt, cone spacer, hat spacer, and nylock nut.
 - Build the recommended stack from the bottom up on the steering arm.
 - On final assembly, torque to 60 ft.lb.



NOTE: The steering arm is a highly tunable tool. Your application will determine how you want to control the bump steer.

Figure 24: Order of bolts on the steering arm

4.0 TORQUE/ALIGNMENT

[Back to Table of Contents](#)

FINAL TORQUE CHECKLIST AND 500-MILE CHECKLIST

This needs to be performed before you hit the road. It also needs to be check after the first 500 miles to ensure safety. It will also be a quick reference for routine maintenance schedule.

Bolt	Location	Torque	1 st Check	500mi Check
1/2" x 2 1/4"	Lower Arm Mount	60 ft.lb.		
3/8" Nylock	Push Rod Mount	20 ft.lb.		
1/2" x 1 3/4"	Upper Arm Mount	60 ft.lb.		
3/8"	Sway Bar Link	35 ft.lb.		
5/8"	Toe Bar	60 ft.lb.		
Grease	Control Arms			

Figure 25: Check list with final torque

ALIGNMENT

WARNING: Do not drive the car before having a professional wheel alignment performed.

NOTE: Use our suggested alignment specifications, do NOT allow the alignment shop to use pre-programmed factory alignment specifications! If your chosen alignment shop cannot match our suggestions, find a different shop familiar with performance alignment set-up.

These are only provided as a suggested starting point and may need refinement to achieve the optimum settings for your driving style or situation. If you are unsure which set-up to use, please call our technical department for help at (435) 628-4300.

DAILY DRIVING	TRACK DRIVING
0 Toe	0 Toe
0 Deg. Negative Camber	-1 1/2" (-1.5) Deg. Negative Camber

Figure 26: Alignment table

5.0 WARRANTY

[Back to Table of Contents](#)

DIFFERENTIAL CARE, BREAK-IN, and WARRANTY INFORMATION

OIL REQUIREMENTS

For Tru Trac and Wavetrack posi units, use a quality petroleum/mineral-based oil. **The Manufacturers do not recommend synthetic oil.** Friction additive/modifier is not required. Do not use any RedLine, Shockproof, Royal Purple or similar gear oils. Specifically, any standard 75W 90 or 140 will work just fine.

OIL LEVEL

Many differentials are easy to fill with gear oil. However, the 9" Ford design can be difficult to fill completely. The location of the fill plug on the 9" Ford can cause oil to run back out before it is completely full. Most 9" housings hold at least 2 1/2 – 3 quarts of oil and sometimes as much as 5 quarts. It is important to take your time and be sure that the oil has settled into all the crevices and recheck the oil level to be certain that it is completely full before driving the vehicle.

BREAK IN

Any overloading or overheating will cause the gear oil to break down and the ring & pinion will fail. All new gear sets require a break-in period to prevent damage from overheating. After driving the first 15 to 20 miles, it is best to stop and let the differential cool before proceeding. Dutchman's warranty requires at least 500 miles before towing. DMI also requires towing for very short distances (less than 15 miles) and letting the differential cool before continuing during the first 45 towing miles. This may seem unnecessary, but it is very easy to damage the differential by loading it before the gear set is completely broken in. DMI recommends changing the oil after the first 500 miles. This will remove any metal particles or phosphorus coating that has come from the new gear set. The greatest damage results when a new ring & pinion has been run for several miles during the first 500 miles and the oil is very hot. Any heavy use or overloading at this time will cause irreparable damage to the gear set that can be determined by inspection and will not be warranted by DMI.

CLUTCH TYPE "POSITRACTIONS"

Posi-traction chatter is normal for limited slip and clutch type posi-traction differentials. Both rear tires must measure the same circumference in order for the differential to function properly without premature wear. **Limited slip additive or friction modifier for limited slip differentials must be used with the oil to reduce positraction chatter in the event that the oil is changed.**

LOCKERS

Mechanical Locking differentials will bang and clunk during normal operation. Both rear tires must measure the same circumference in order for a locking differential to function properly.

GEAR NOISE

Richmond Gear and other aftermarket (non-OEM) gears are designed primarily for strength **and may be noisy**. This noise is especially inherent in vans and quiet passenger cars. **No gear manufacturer warrants their product or set up to be 100% quiet.**

SIGNS OF LUBRICATION FAILURE

When a gear runs low on oil, damage is sure to result. The cause of damage is not always obvious. When a differential runs low on oil, the oil volume may not be sufficient to keep the gear cool. Once the oil breaks down from contact with the hot gear, wear occurs very rapidly. Material will wear off the drive side of both the ring & pinion teeth and leave a feather like pattern on both surfaces. A gear that wears from friction due to lack of lubrication and excessive heat seldom experiences a color change from heat because any discoloration is worn off the teeth during each contact. Ring & Pinion gears are heat treated separately so that the pinion, whose teeth make contact more often than the ring gear, is designed to be harder. To accomplish this, the two gears are heat treated separately and a soft gear will not cause both the ring & pinion to wear.

DUTCHMAN AXLE WARRANTY EXCLUSIONS

1. Any damage due to abuse, overloading, or lubrication failure (e.g. oil deterioration, water contamination, low oil level).
2. Any vehicles used off road or for competition.
3. Mini and mid-sized vehicles with tires over 31" tall will not be warranted due to the overloading caused by tall tires.

Most items are not warranted against abuse, overloading, or improper lubrication. All rear axle parts must be returned to DUTCHMAN'S shop freight prepaid for inspection and determination. We do not authorize and will not pay for outside repairs. **Any unauthorized outside repairs or modifications void this warranty.** We will not pay for labor, inconvenience, loss of time or revenue, telephone calls, commercial losses, or loss of perishable goods. This is our only warranty expressed or implied. All returned goods must be accompanied by copy of purchase invoice within 30 days and will be charged a 20% service charge for handling.

6.0 CONGRATULATIONS

[Back to Table of Contents](#)

Congratulations on completing your project! We know you will get many years of enjoyment from your project. Please join the group, [Team Speedtech](#), on Facebook. Team Speedtech is a community of customers, dealers, and factory employers that have a passion for pro touring muscle cars and are using Speedtech Performance products. You can ask questions and get advice from the group members and share your experience. Everyone enjoys seeing the videos and pictures during the progress of your project and Speedtech encourages you to share them!

Thank you for choosing Speedtech Performance and entrusting us with your independent rear suspension for your custom muscle car.

Speedtech Performance, LLC
4160 S. River Rd.
St George UT, 84770
(435) 628-4300