

Instruction Guide

Enhanced Ackermann Kit
71-72 A-Body



Speedtech
PERFORMANCE

CHASSIS - SUSPENSION - PRO TOURING - AUTOCROSS - DRAG RACING - CUSTOM BUILDS

435.628.4300 SPEEDTECHPERFORMANCE.COM    

4160 S. RIVER RD, ST. GEORGE, UT 84790



Figure 1: 1969 Chevelle features our Bump Steer kit [photo by: @boy_andy]

Congratulations on the purchase of your new Speedtech Performance Ackermann Kit. Use only approved and appropriately rated jack and jack stands, and be sure to take all safety precautions required to complete the job safely and correctly. If you have uncertainties, seek the assistance of a highly qualified workshop to assist you.

Read and understand all instructions thoroughly before you begin. Your main assembly and set up of your new Ackermann can be done in a home garage with hand tools.

Speedtech enjoys seeing the progress our customers are making as they work through their builds. Join the group, [Team Speedtech](#), on Facebook and share your pictures and your story.

Speedtech Performance sends you best wishes for your project!

TABLE OF CONTENTS

1.0	GENERAL INFORMATION.....	4
1.1	THIS GUIDE.....	4
1.2	OVERVIEW.....	4
1.3	TOOLS.....	4
2.0	CHECK IN PARTS AND HARDWARE.....	5
2.1	CHECKING IN THE ORDER.....	5
2.2	CHECK IN TABLE.....	5
3.0	GETTING STARTED / INSTALLATION.....	6
3.1	LEVELING AND SUPPORT.....	6
3.2	STEERING ARMS / LINKAGE REMOVAL.....	6
3.3	JAM NUTS.....	6
3.4	PREPPING SLEEVES.....	7
3.5	REPEAT.....	7
4.0	ALIGNMENT / SET UP.....	7
4.1	ALIGNMENT.....	8
5.0	FINAL STEPS.....	9
6.0	CONCLUSION.....	9

1.0 GENERAL INFORMATION

[Back to Table of Contents](#)

1.1 THIS GUIDE

Thank you for purchasing your new Speedtech Performance enhanced Ackermann kit. Read through all instructions thoroughly before beginning and take all safety precautions required to do the job carefully and correctly.

The following instructions are intended for professional installers and are guidelines only. Speedtech Performance assumes no responsibility for the installation of any of its products installed by others. All products are intended to be installed by qualified professionals. However, if you have uncertainty, seek the assistance of a highly qualified workshop.

1.2 OVERVIEW

These instructions outline the enhanced Ackermann kit that will be installed with the Speedtech Performance forged tall spindle. Photos in the instruction process may vary slightly from your exact operation.

1.3 TOOLS

Installation of the Speedtech Performance ExtReme enhanced Ackermann kit can be done on the floor with simple hand tools.

Additional things to have before you start:

- Wrench
- Jack Stands

2.0 CHECK IN PARTS AND HARDWARE

[Back to Table to Contents](#)

2.1 CHECKING IN THE ORDER

Check in your order as soon as possible. To check in the order, Speedtech has provided a table which can be used as a check list, as displayed in figure 2. All bolts and nuts are NF unless otherwise noted. Hardware comes in several boxes. If you discover anything missing from your order, call your authorized dealer as soon as possible.

2.2 CHECK IN TABLE

X	#	Description	Size
	2	Billet Long Tie Rod Sleeves	
	2	Billet Steering Arms	
	2	RHT Jam Nuts	
	2	LHT Jam Nuts	

Figure 2: Check in table with the amounts and descriptions

NOTE: There may be some extra hardware that was packaged and is not accounted for in the check list. The hardware kits are made to fit multiple products; hence why there may be a surplus of supplies.

3.0 GETTING STARTED / INSTALLATION

[Back to Table of Contents](#)

3.1 LEVELING AND SUPPORT

WARNING: The vehicle should be on a level surface before you start.

First, jack up and properly support the vehicle's frame. The suspension should be at drive height when installing the bar. If the car is on a lift and the suspension is in droop when you install the kit, it will not line up properly when back on the ground. The sway bar brackets will all need to be testfit into place before final installation to achieve proper alignment of the bar and that no binding is experienced during the suspension's travel.

The enhanced Ackermann kit gets installed after your Speedtech Performance forged tall spindle (see spindle instructions).

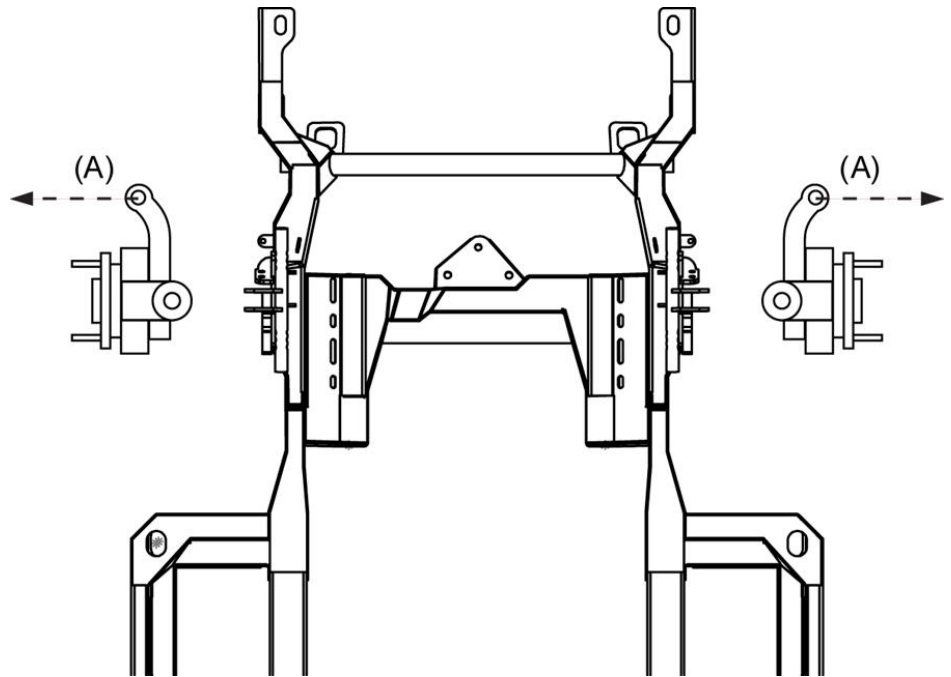

Figure 3: Steering arms/linkage removal

3.2 STEERING ARMS / LINKAGE REMOVAL

Install steering arms with the tie rod ends pointing towards the outside of the car, as presented in (A) in figure 3. Remove the old outer tie rods and adjusting sleeves from the steering linkage. Do not remove the inner tie rods from the center link unless they need to be replaced.

3.3 JAM NUTS

Thread a jam nut several threads onto both the rod end and the inner tie rod. Pay close attention to using the correct nut thread direction in the appropriate corresponding locations.

NOTE: 1 is left hand and 1 is right hand.

3.4 PREPPING SLEEVES

Apply anti-seize to the threads on both ends of the adjuster sleeves. Thread the machined end of one adjuster sleeve (see diagram below) a couple of threads onto one inner tie rod. Thread one heim joint the same number of threads into the other end of the adjuster. Holding the heim joint steady use the other hand to rotate the adjuster sleeve so that it simultaneously tightens down both sides an equal amount until it lines up with the spindle steering arm with the wheel pointed straight forward.

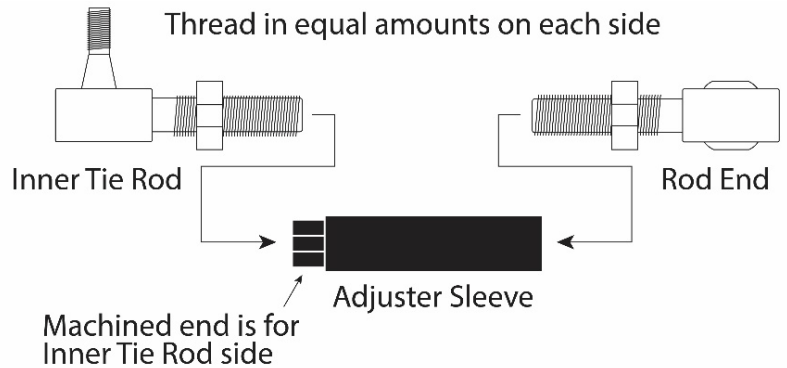

Figure 4: Steering arms/linkage removal

NOTE: Figure 4 shows a rod end on the outer which is not supplied in this kit - you will be using the factory outer tie rod end with the supplied jam nuts.

3.5 REPEAT

Repeat steps 3.2-3.4 on the other side of the car.

4.0 ALIGNMENT / SET UP

[Back to Table of Contents](#)

Using a center point on the frame as a reference align the middle of the center link to the center of the vehicle. Now with the suspension at ride height and the wheels and tires bolted in place adjust each side's toe setting by turning the adjuster sleeves equally either forward or backward until the tires are facing forward. You can get the toe setting fairly close by adjusting the suspension until measuring the distance between the same points on the front side of each tire is equal to the distance between the same points on the rear side of each tire, see (X) in figure 5. Adjust as needed until both front and rear measurements are near the same. When finished snug all four jam nuts finger tight. This will be close enough to drive the car onto a trailer to take to a competent alignment shop.

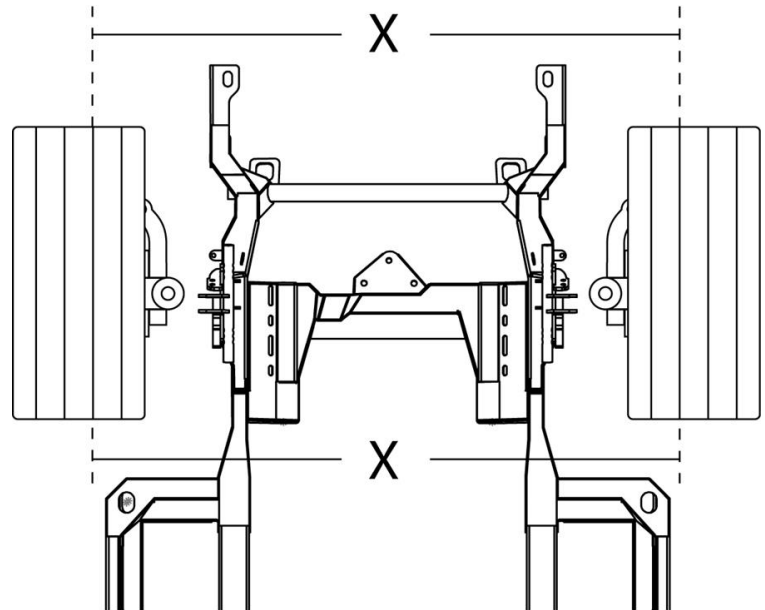

Figure 5: Toe setting

IMPORTANT! Do not street drive the car in this condition other than to load it on a trailer.

4.1 ALIGNMENT

Bring the car to a reputable alignment shop that is familiar with performance alignment settings and how they all correlate with each other. They must be familiar, but not limited, to the following: the caster, camber gain, toe settings for specific types of driving/racing, bump steer adjustment, etc.

When the alignment is finalized the alignment technician will then tighten the tie rod adjuster jam nuts.

The following are the specifications needed for alignment, unless noted otherwise.

Daily Driving, Street Performance Specifications

Driver Side	Passenger Side
4 Degrees positive Caster	4 ½ Degrees positive Caster
0 to ½ Degree negative Camber	0 to ½ Degree negative Camber
3/ 32 Total Toe-in	3/ 32 Total Toe-in

Aggressive Track Alignment Specifications

Driver Side	Passenger Side
5 ½ Degrees positive Caster	6 Degrees positive Caster
½ to 1 Degree negative Camber	½ to 1 Degree negative Camber
3/ 32 Total Toe-in	3/ 32 Total Toe-in

Original Alignment Specifications

****For reference purposes only. Do Not use these specs.**

Driver Side	Passenger Side
½ Degree positive Caster	½ Degree positive Caster
¼ to ½ Degree negative Camber	¼ to ½ Degree negative Camber
1/8 Total Toe-in	1/8 Total Toe-in

Figure 6: Three charts depicting the alignment settings

5.0 FINAL STEPS

[Back to Table of Contents](#)

Be sure that all measurements are correct and double-check that all components have proper clearance throughout your suspension's travel range. Torque all bolts to spec. Tighten all loose suspension bolts and double-check all bolts to ensure they are all tight. (It is recommended you fill all grease fittings at this time. Speedtech suggests using Permatex Ultra Slick Synthetic Grease, but any high-quality chassis grease will do. For your Sweet power rack and pinion we recommend using Sweet or Jones brand full synthetic power steering fluid for best performance and to avoid overheating standard type fluids during performance driving situations.

This concludes the instructions for the enhanced Ackermann and bump steer adjustment kit.

6.0 CONCLUSION

[Back to Table of Contents](#)

Congratulations on completing your project! We know you will get many years of enjoyment from your project. Please join the group, [Team Speedtech](#), on Facebook. Team Speedtech is a community of customers, dealers, and factory employers that have a passion for pro touring muscle cars and are using Speedtech Performance products. You can ask questions and get advice from the group members and share your experience. Everyone enjoys seeing the videos and pictures during the progress of your project and Speedtech encourages you to share them!

Thank you for choosing Speedtech Performance and entrusting us with your Ackermann and bump steer adjustment kit needs for your custom muscle cars.

Speedtech Performance, LLC
4160 S. River Rd.
St George UT, 84770
(435) 628-4300