

# Instruction Guide

Bump Steer Adjustment Kit  
67-69 F-Body



**Speedtech**  
PERFORMANCE

CHASSIS - SUSPENSION - PRO TOURING - AUTOCROSS - DRAG RACING - CUSTOM BUILDS

435.628.4300 SPEEDTECHPERFORMANCE.COM



4160 S. RIVER RD, ST. GEORGE, UT 84790



*Figure 1: 1967 Camaro features our suspension components*

Congratulations on the purchase of your new Speedtech Performance bump steer adjustment kit. Use only approved and appropriately rated jack and jack stands, and be sure to take all safety precautions required to complete the job safely and correctly. If you have uncertainties, seek the assistance of a highly qualified workshop to assist you.

Read and understand all instructions thoroughly before you begin. Your main assembly and set up of your new bump steer adjustment kit can be done in a home garage with hand tools.

Speedtech enjoys seeing the progress our customers are making as they work through their builds. Join the group, [Team Speedtech](#), on Facebook and share your pictures and your story.

Speedtech Performance sends you best wishes for your project!

# TABLE OF CONTENTS

<b>1.0</b>	<b>GENERAL INFORMATION.....</b>	<b>4</b>
1.1	THIS GUIDE.....	4
1.2	OVERVIEW.....	4
1.3	TOOLS.....	4
<b>2.0</b>	<b>CHECK IN PARTS AND HARDWARE.....</b>	<b>4</b>
2.1	CHECKING IN THE ORDER.....	4
2.2	CHECK IN TABLE.....	5
<b>3.0</b>	<b>GETTING STARTED.....</b>	<b>5</b>
3.1	LEVELING AND SUPPORT.....	5
3.2	TIE ROD REMOVAL.....	5
3.3	MACHINING.....	5
<b>4.0</b>	<b>INSTALLATION.....</b>	<b>6</b>
4.1	JAM NUTS.....	6
4.2	ADJUSTER SLEEVE.....	6
4.3	SHIMS.....	7
4.4	REPEAT.....	8
<b>5.0</b>	<b>ALIGNMENT.....</b>	<b>8</b>
5.1	INITIAL/BASIC ALIGNMENT.....	8
5.2	ALIGNMENT.....	8
<b>6.0</b>	<b>FINAL STEPS.....</b>	<b>10</b>
<b>7.0</b>	<b>CONGRATULATIONS.....</b>	<b>10</b>

## **1.0 GENERAL INFORMATION**

[Back to Table of Contents](#)

### **1.1 THIS GUIDE**

Thank you for purchasing your new Speedtech Performance bump steer adjustment kit which has been designed to work with your factory subframe or chassis. Read through all instructions thoroughly before beginning and take all safety precautions required to do the job carefully and correctly.

The following instructions are intended for professional installers and are guidelines only. Speedtech Performance assumes no responsibility for the installation of any of its products installed by others. All products are intended to be installed by qualified professionals. However, if you have uncertainty, seek the assistance of a highly qualified workshop.

### **1.2 OVERVIEW**

These instructions outline the Bump Steer Adjustment Kit. Some photos in the installment process may vary slightly from your exact application. For example, this guide only contains pictures of the bump steer adjustment kit for the early Camaro. Your application may have a slightly different shape; the part is functionally the same and is installed in the same manner described.

### **1.3 TOOLS**

Installation of the Speedtech Performance bump steer adjustment kit can be done on the floor with simple hand and power tools. You will be required to drill/machine some holes.

Additional things to have before you start:

- Wrench/Socket
- Drill
- Floor Stands
- Floor Jack
- Torque Wrench
- Anti-Seize

## **2.0 CHECK IN PARTS AND HARDWARE**

[Back to Table of Contents](#)

### **2.1 CHECKING IN THE ORDER**

Check in your order as soon as possible. To check in the order, Speedtech has provided a table which can be used as a check list, as displayed in figure 2. All bolts and nuts are NF unless otherwise noted. Hardware comes in several boxes. If you discover anything missing from your order, call your authorized dealer as soon as possible.

## 2.2 CHECK IN TABLE

X	#	Description	Size
	2	Billet Tie Rod Sleeve	
	2	Heim Joint	
	2	Shoulder Bolt	5/8"
	2	Nylock Nut	
	2	Right Hand Thread Jam Nut	
	2	Left Hand Thread Jam Nut	
	1	Pack Tall Shims	5/8"
	1	Pack Short Shims	5/8"
	4	Aluminum Heim Spacer	

Figure 2: Check in table that includes the amounts, descriptions, and sizes

## 3.0 GETTING STARTED

[Back to Table of Contents](#)

### 3.1 LEVELING AND SUPPORT

**WARNING:** The vehicle should be on a level surface before you start.

First, jack up and properly support the vehicle's frame. Remove the front wheels. For cars with drop off style rotors, reinstall one lug nut, if needed, to prevent the rotor from falling off.

### 3.2 TIE ROD REMOVAL

Remove the old outer tie rods and adjusting sleeves from the steering linkage. Do not remove the inner tie rods from the center link unless they need to be replaced.

### 3.3 MACHINING

This kit uses a 5/8 diameter shoulder bolt to attach the rod end to the spindle's steering arm. Because the arm has a taper to match the tie rod end pin, your steering arm must be machined to remove the taper and match the bolt's diameter. Most machine shops will perform this; however, you will have to remove the steering arms from your spindles. Because the bolts are manufactured slightly under 5/8" and have very slight manufacturing tolerances, be sure to bring your shoulder bolts to your machine shop so that they can measure their diameter and machine the steering arm to the appropriate size.

Figure 3: Machining



**NOTE:** In Speedtech's machining process they use a .623 reamer for the final size.

The end result should be a bolt that fits snug in the bore but not so tight as it needs to be pressed in.

**WARNING:** Simply drilling the steering arms with a 5/8 drill bit may have too much clearance and may cause the bolt to be too loose in the bore. This could lead to premature wear and a potentially dangerous situation. Do not shortcut this step.

After final assembly, the bolt and spacers along with the steering arm should tighten down tight to the rod end which will then rotate within itself.

## 4.0 INSTALLATION

[Back to Table of Contents](#)

### 4.1 JAM NUTS

Thread a jam-nut several threads onto both the rod end and the inner tie rod. Pay close attention to using the correct nut left hand or right hand thread direction in the appropriate corresponding locations.

### 4.2 ADJUSTER SLEEVE

Apply anti-seize to the threads on both ends of the adjuster sleeves. Thread one adjuster sleeve a couple of threads onto one inner tie rod, paying close attention to using the correct thread direction. If you find the sleeve won't thread on, try threading the opposite end instead. Thread one rod end the same number of threads into the other end of the adjuster, as presented in figure 4.

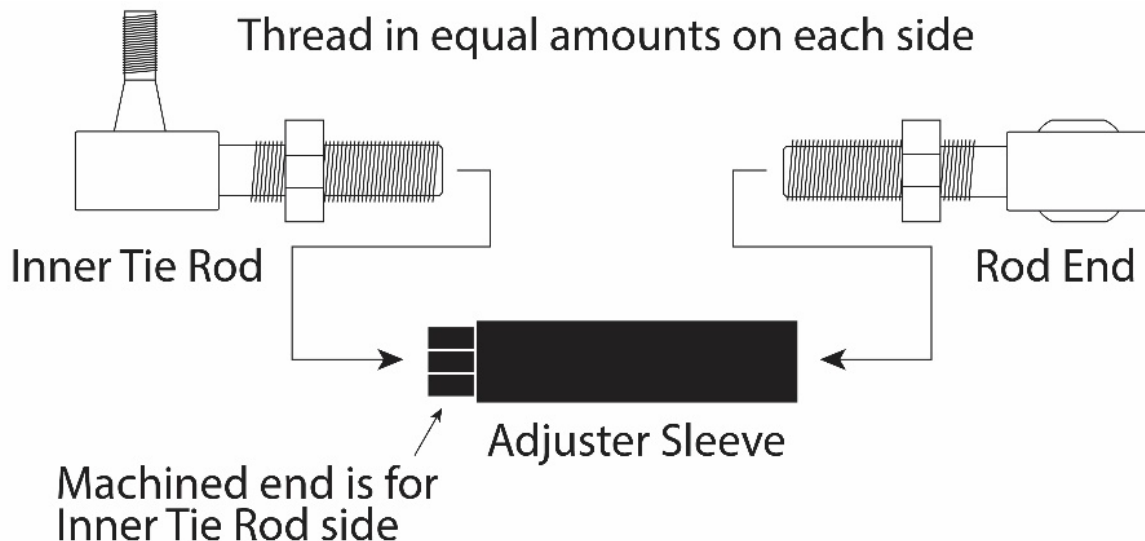

Figure 4: Threading equal amounts on each side

Holding the rod end steady, use the other hand to rotate the adjuster sleeve so that it simultaneously tightens down both sides an equal amount of times until it lines up with the spindle steering arm and the wheel pointed straight forward.

### 4.3 SHIMS

Install the shims, shoulder bolt, and nylock nut as seen in figure 5. If necessary, change the positioning order of the shims to have the tie rod assembly close to parallel with the ground, with the assembly mocked up at ride height. This will give you a good base bump steer setting to start with. Finger tighten the nylock nut, but do not fully tighten it at this point.

**NOTE:** On some after-market wheels, you may need to remove the lower thin aluminum spacer washer to maintain clearance. Minimum clearance to the wheel should be .125”.

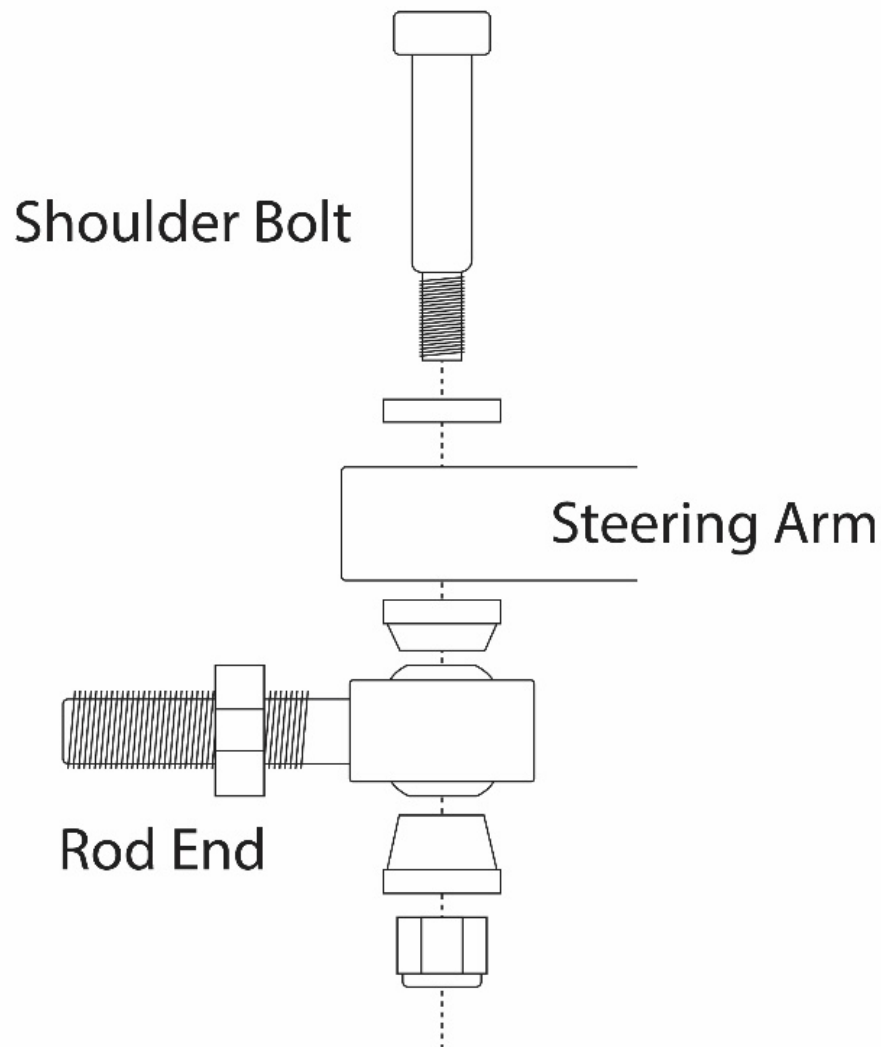

Figure 5: Installing the shoulder bolts, steering arms, and rod ends

#### 4.4 REPEAT

Repeat steps 1-3 on the other side of the car.

### 5.0 ALIGNMENT

[Back to Table of Contents](#)

#### 5.1 INITIAL/BASIC ALIGNMENT

Using a center point on the frame as a reference align the middle of the center link to the center of the vehicle. Now with the suspension at ride height and the wheels and tires bolted in place adjust each side's toe setting by turning the adjuster sleeves equally either forward or backward until the tires are facing forward. You can get the toe setting fairly close by adjusting the suspension until measuring the distance between the same points on the front side of each tire is equal to the distance between the same points on the rear side of each tire, see (X) in figure 6. Adjust as needed until both front and rear measurements are near the same. When finished snug all four jam nuts finger tight. This will be close enough to drive the car onto a trailer to take to a competent alignment shop.

**IMPORTANT:** Do not street drive the car in this condition other than to load it on a trailer.

*Figure 6: Toe setting*

#### 5.2 ALIGNMENT

When finished, take the vehicle to a competent professional alignment shop to have an alignment performed.

**NOTE:** Use alignment specifications below, not alignment shop pre-programmed factory specs.

These specs are only suggestions and may need additional changes to achieve the optimum settings for your driving style or situation.

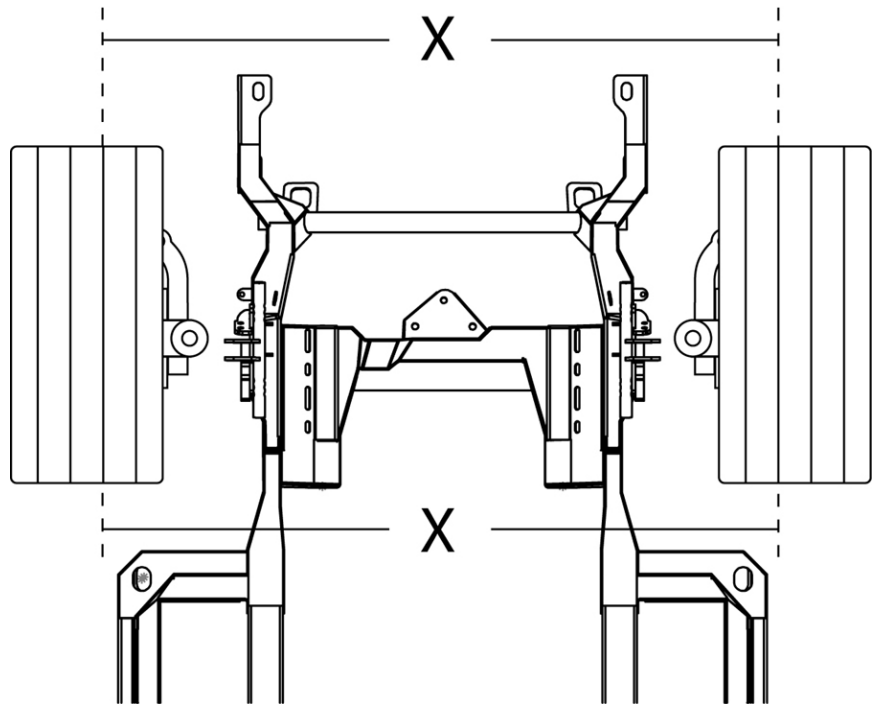

### Daily Driving, Street Performance Specifications

<b>Driver Side</b>	<b>Passenger Side</b>
4 Degrees positive Caster	4 ½ Degrees positive Caster
0 to ½ Degree negative Camber	0 to ½ Degree negative Camber
3/ 32 Total Toe-in	3/ 32 Total Toe-in

### Aggressive Track Alignment Specifications

<b>Driver Side</b>	<b>Passenger Side</b>
5 ½ Degrees positive Caster	6 Degrees positive Caster
½ to 1 Degree negative Camber	½ to 1 Degree negative Camber
3/ 32 Total Toe-in	3/ 32 Total Toe-in

### Original Alignment Specifications

\*\*For reference purposes only. Do not use these specs.

<b>Driver Side</b>	<b>Passenger Side</b>
½ Degree positive Caster	½ Degree positive Caster
¼ to ½ Degree negative Camber	¼ to ½ Degree negative Camber
1/8 Total Toe-in	1/8 Total Toe-in

## 6.0 FINAL STEPS

[Back to Table of Contents](#)

Be sure that all measurements are correct and double-check that all components have proper clearance throughout your suspension's travel range. Torque all bolts to spec. Tighten all loose suspension bolts and double-check all bolts to ensure they are all tight. (It is recommended you fill all grease fittings at this time. Speedtech suggests using Permatex Ultra Slick Synthetic Grease, but any high-quality chassis grease will do.) For your Sweet power rack and pinion we recommend using Sweet or Jones brand full synthetic power steering fluid for best performance and to avoid overheating standard type fluids during performance driving situations.

This concludes the instructions for the bump steer adjustment kit.

## 7.0 CONGRATULATIONS

[Back to Table of Contents](#)

Congratulations on completing your project! We know you will get many years of enjoyment from your project. Please join the group, [Team Speedtech](#), on Facebook. Team Speedtech is a community of customers, dealers, and factory employers that have a passion for pro touring muscle cars and are using Speedtech Performance products. You can ask questions and get advice from the group members and share your experience. Everyone enjoys seeing the videos and pictures during the progress of your project and Speedtech encourages you to share them!

Thank you for choosing Speedtech Performance and entrusting us with your bump steer adjustment kit needs for your custom muscle cars.

Speedtech Performance, LLC  
4160 S. River Rd.  
St George UT, 84770  
(435) 628-4300