

Instruction Guide

55-59 GM Truck Front Frame Horns



Speedtech
PERFORMANCE

CHASSIS - SUSPENSION - PRO TOURING - AUTOCROSS - DRAG RACING - CUSTOM BUILDS

435.628.4300 SPEEDTECHPERFORMANCE.COM    

4160 S. RIVER RD, ST. GEORGE, UT 84790



Congratulations on the purchase of your new Speedtech Performance ExtReme front frame horns. Use only approved and appropriately rated jack and jack stands, and be sure to take all safety precautions required to complete the job safely and correctly. If you have uncertainties, seek the assistance of a highly qualified workshop to assist you.

Read and understand all instructions thoroughly before you begin. Your main assembly and set up of your new ExtReme front frame rails can be done in a home garage with hand tools and basic welding equipment.

Speedtech enjoys seeing the progress our customers are making as they work through their builds. Join the group, [Team Speedtech](#), on Facebook and share your pictures and your story.

Speedtech Performance sends you best wishes for your project!

TABLE OF CONTENTS

| | | |
|------------|---|----------|
| 1.0 | GENERAL INFORMATION..... | 4 |
| 1.1 | THIS GUIDE..... | 4 |
| 1.2 | OVERVIEW..... | 4 |
| 1.3 | TOOLS..... | 4 |
| 2.0 | CHECK IN PARTS AND HARDWARE..... | 4 |
| 2.1 | CHECKING IN THE ORDER..... | 4 |
| 2.2 | CHECK IN TABLES..... | 5 |
| 3.0 | FRONT FRAME HORNS..... | 5 |
| 3.1 | 55-57 V8..... | 5 |
| 3.2 | 55-57 IN-LINE 6..... | 5 |
| 3.3 | 58-59 ALL ENGINES..... | 6 |
| 4.0 | CONGRATULATIONS..... | 6 |

1.0 GENERAL INFORMATION

[Back to Table to Contents](#)

1.1 THIS GUIDE

The following instructions are intended for professional installers and are guidelines only. Speedtech Performance assumes no responsibility for the installation of any of its products installed by others. All products are intended to be installed by qualified professionals.

1.2 OVERVIEW

These instructions outline the '55-59 GM Truck Chassis front frame horns and the variations therein. You will receive three sets of core mounting brackets, and will determine which works for your set up.

NOTE! The front horn has two bumper mounting locations for different years.

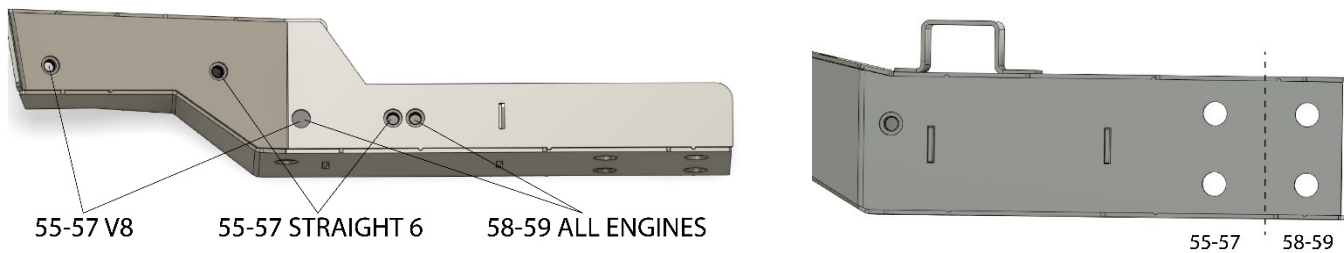

1.3 TOOLS

Installation of the Speedtech Performance 55-59 GM Truck Chassis can be done on the floor with simple hand tools.

Tools to have before you start:

- Grinder
- Wrench/Socket

2.0 CHECK IN PARTS AND HARDWARE

[Back to Table of Contents](#)

2.1 CHECKING IN THE ORDER

Check in your order as soon as possible. To check in the order, Speedtech has provided tables which can be used as check lists. All bolts and nuts are NF unless otherwise noted. Hardware comes in several boxes. If you discover anything missing from your order, call your authorized dealer as soon as possible.

2.2 CHECK IN TABLES

| | | |
|---|-------------------|--|
| 2 | 55-57 V8 | |
| 2 | 55-57 IN-LINE 6 | |
| 2 | 58-59 ALL ENGINES | |

3.0 FRONT FRAME HORNS

3.1 55-57 V8

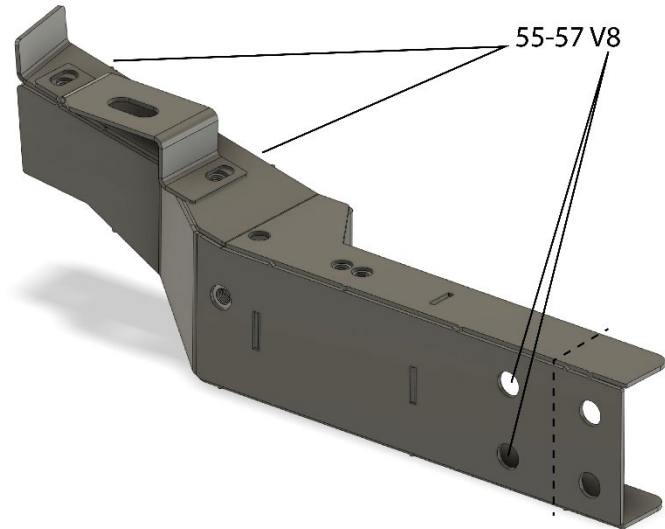

3.2 55-57 IN-LINE 6

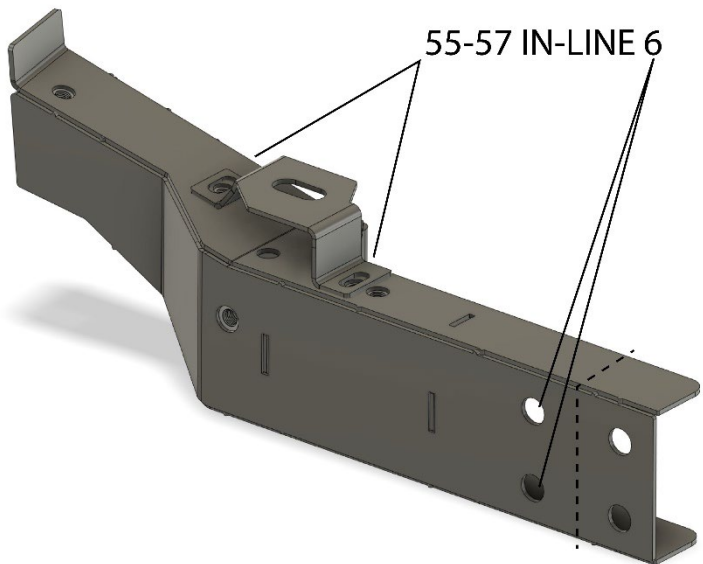

3.3 58-59 ALL ENIGINES

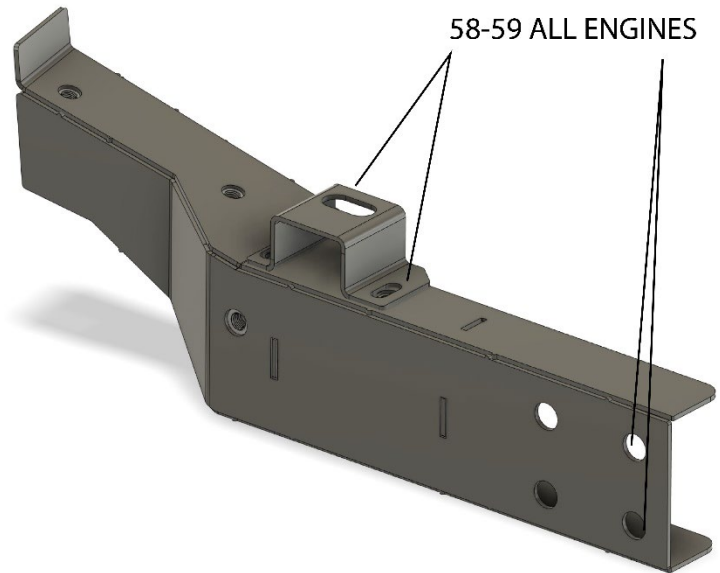

4.0 CONGRATULATIONS

[Back to Table of Contents](#)

Congratulations on completing your project! We know you will get many years of enjoyment from your project. Please join the group, [Team Speedtech](#), on Facebook. Team Speedtech is a community of customers, dealers, and factory employers that have a passion for pro touring muscle cars and are using Speedtech Performance products. You can ask questions and get advice from the group members and share your experience. Everyone enjoys seeing the videos and pictures during the progress of your project and Speedtech encourages you to share them!

Thank you for choosing Speedtech Performance and entrusting us with your chassis and suspension needs for your custom muscle car.

Speedtech Performance, LLC
4160 S. River Rd.
St George UT, 84770
(435) 628-4300