

By MAVAL  
**UNI STEER**  
**P E R F O R M A N C E**

**'67-69 Camaro / '68-74 Nova Power Rack & Pinion  
# 8010540-01, 8010540-02**

UniSteer offers a 2-year, unlimited mile warranty against all manufacturer defects of their kits and supplied parts. UniSteer will not honor any warranty on any parts that have been modified or improperly installed. Full refund will NOT be granted to any kits that are damaged, scratched, or altered in any fashion. UniSteer will not reimburse any labor money to the customer to change out the part even under a warranty repair.



**USE ONLY POWER STEERING FLUID IN SYSTEM. DO NOT USE ATF.**

**ALTHOUGH THIS KIT IS FAIRLY SIMPLE TO INSTALL SOME MODIFICATIONS ARE NECESSARY TO INSTALL.**

**BEFORE STARTING BE AWARE OF THE MODIFICATIONS NEEDED.**

**ALSO BE AWARE THAT THERE ARE APPLICATION/PROVISIONS NEEDED IN ORDER TO INSTALL. PLEASE READ ALL INSTRUCTIONS FIRST.**

**DUE TO VARIABLES OUTSIDE OUR CONTROL THESE KITS MAY NOT FIT ALL APPLICATIONS. ALSO, PLEASE VERIFY KIT WILL FIT YOUR APPLICATION BEFORE ALTERING VEHICLE.**

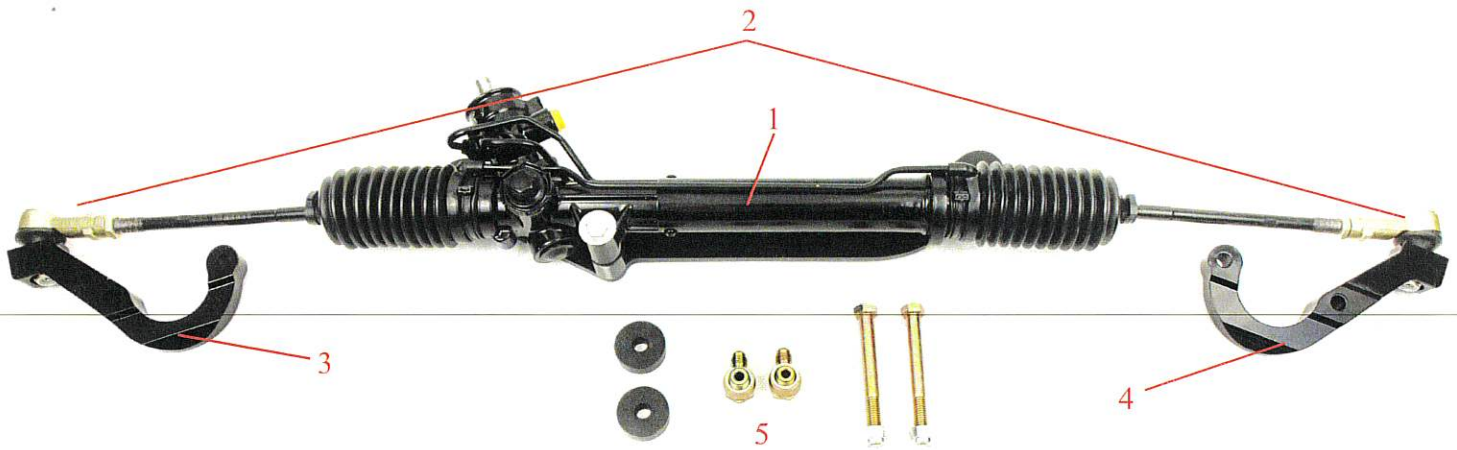

**Kit Contents:**

#	Part Number	Description	Quantity	Inspected By
1	8010550	Power Rack & Pinion	1	
2	10002	Outer Ends	2	
3	8020720	DS Steering Arm	1	
4	8020730	PS Steering Arm	1	
5	620410	Install Kit	1	
	--120480	- 1/2"-13 Lock Nut	2	
	--205650	- Stand Off	2	
	--230790	- 1/2"-13 x 4 1/2" Hex Bolt	2	
	--621710	- 16mm & 18mm Banjo Fitting Kit	1	

**Applications/Provisions**

This rack and pinion kit is designed specifically for 1967-69 Camaro (NOT Firebird) & 1968-74 Nova's. The kit is compatible with both big block and small block Chevy motors. Two new steering arms are included and **MUST** be used. If you are using aftermarket spindles that have the steering arms permanently fixed, they **MUST** be replaced. There are aftermarket spindles that accept our arms.

The rack and pinion work with both the factory Camaro power steering pump and the commonly used GM GEN II aluminum TC pump. Either pump will require new hoses. We offer braided stainless hoses for both style pumps. If you are planning on using the GEN II/TC pump, a new bracket, pulley, and reservoir will also be needed. These items can be purchased through Unisteer Performance Products, or from any of our dealers.

This kit also requires installing a new steering shaft between the steering column, and the rack and pinion. The steering shaft is also available through Unisteer Performance Products, but you will need to provide us with the year, engine type, and if you're using a stock column. If you are using an aftermarket column, state what brand. Big Block motors are limited to using certain shape headers, or stock manifolds.

If you're using a stock/factory steering column you will need to purchase a steering column adaptor (sold separately part # 8020820).

For small block and big block vehicles we used Hooker Long Tube Competition Headers in our R&D (. These required no modification however we do not guarantee these to fit every car because of variances between vehicles. All other headers may require modification to fit including Super Competition Headers. We recommend coating your header of choice after the complete kit is installed and all modifications complete.

## Disassembly

In order to perform this installation, the front end of the car must be off the ground. A lift works best, but jack stands will work. No special tools are required, but a bottle jack should be used to help relieve spring pressure on the control arm. **1)** Remove wheels, and brakes, so you're down to bare spindle. There is no need to disconnect the caliper though. **2)** Remove the two bolts holding each of the factory steering arms. Save these since they will be needed to install the new arms. Pull the steering arms away from the spindle. **3)** Remove the bolt holding the steering coupler to the steering box. **4)** Remove the two bolts holding the idler arm, and the three bolts holding the steering box. The entire steering linkage should now be free to be removed from the car.

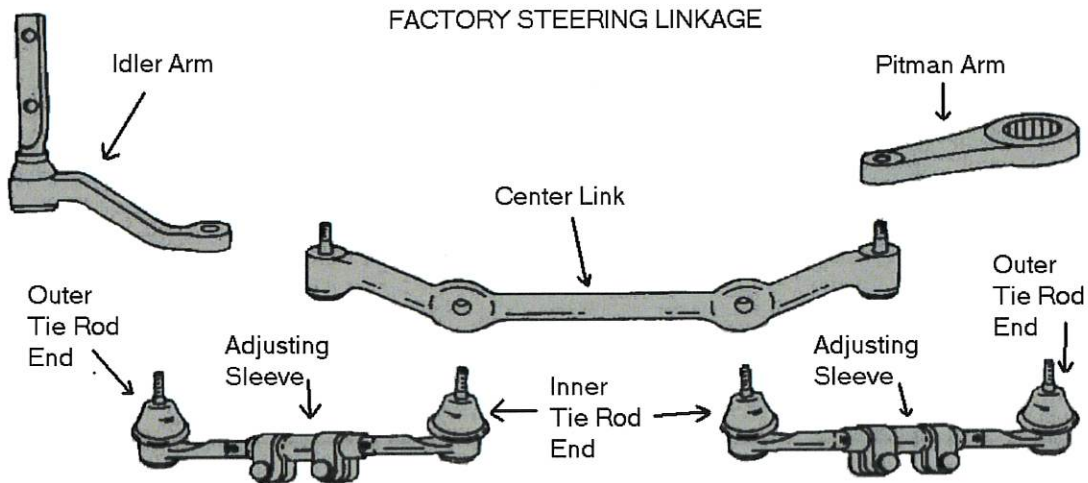

### 1967-'69 Camaro Steering linkage

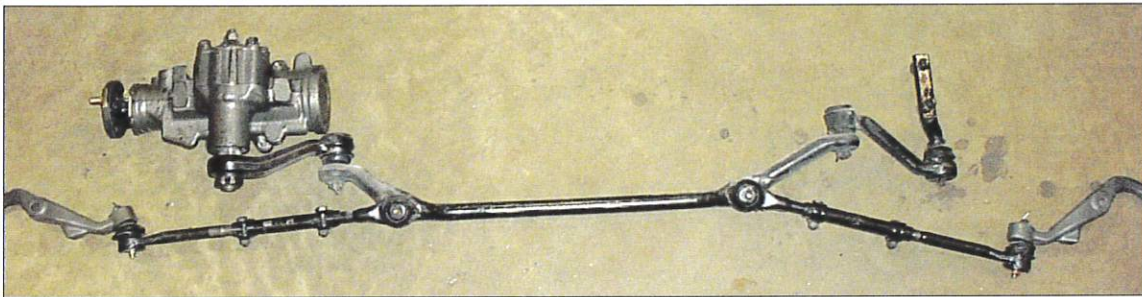

This kit will arrive to you pre-assembled and centered. The mounting bracket attaches to the two rear lower control arm bolts. We provide two new longer bolts to do this. Removing the old control arm bolts can be difficult because the tension of the coil spring. If you jack up the lower control arm using a bottle jack or floor jack, these bolts can be removed much easier. Also inspect the bolt holes to make sure they haven't been elongated. This is also a good time to change the control arm bushings if needed.

## Installation

- 1) Remove the driver side rear lower control arm bolt. To do this use one of the new bolts that is provided and drive the old bolt out with the new bolt. Using the other new bolt, drive the bolt you just installed out so that the threaded end of the new bolt is facing the back of the car. You may need to draw the bolt through by tightening the nut, if so, remove the nut after the bolt has been completely drawn through. Install one of the steel spacers (standoff) provided.

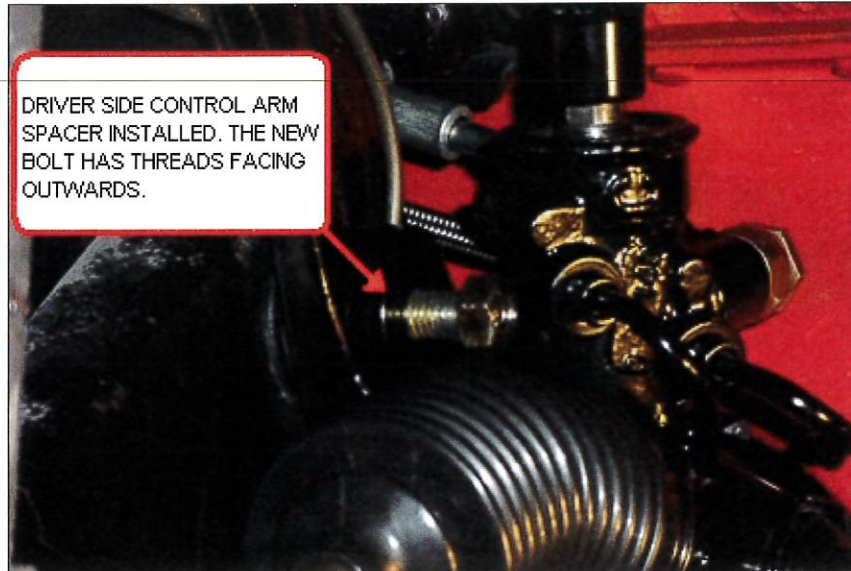

- 2) Prepare to remove the passenger side control arm bolt. Shift the jack to the passenger side.
- 3) After removing the nut, drive the old bolt out using the old driver's side bolt. Take the remaining new bolt and drive out the old bolt you just installed back out so that the treaded end is facing the back of the car. Drive the bolt through, just enough for the stand off and the rack bracket to hang on.

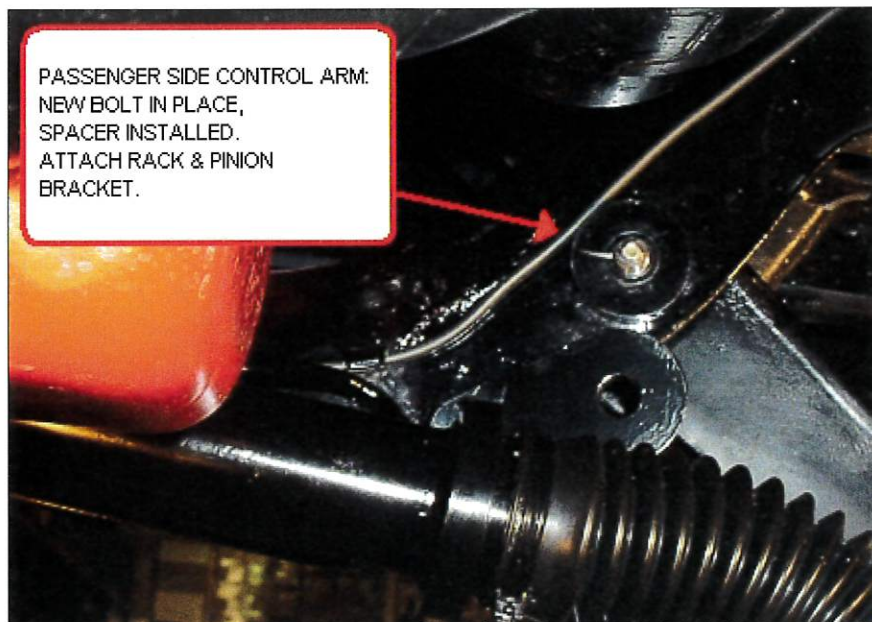

- 4) Hang the new rack and pinion on the two 2 control arm bolts (see above). Install the new nuts and torque to **85 ft/lbs.**
- 5) Install the new steering arms using the factory bolts that you removed earlier (see below). Torque the bolts to **85 ft/lbs.**

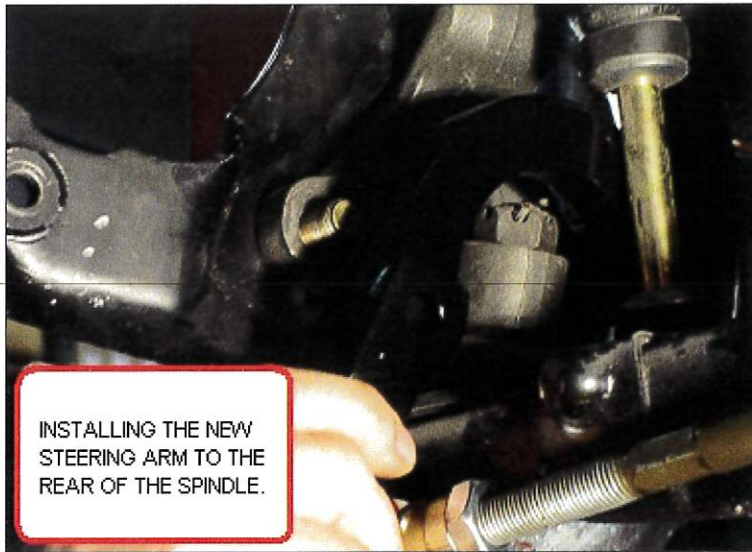

6) Adjust the outer tie rod ends so that each side is on equally (see next page). Insert the outer tie rod stud into the steering arm hole and nut the stud. Torque to **35 ft/lbs.**



## Steering Shaft Installation

\*For factory column, aftermarket column requires different shaft kits, call for assistance.

- 1) Remove the steering coupler from the steering column. This is held in place with two bolts. If you're using an aftermarket column this does not apply.
- 2) Install new column adaptor kit shown below **SOLD SEPERATELY (# 8020820)** by bolting it in place.

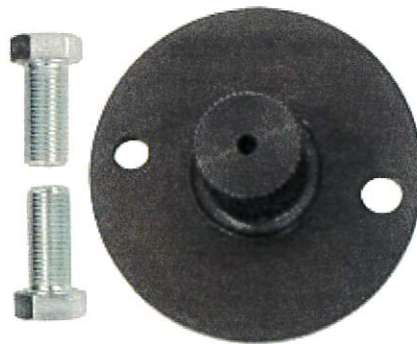

- 3) Mock the new 2-joint SBC steering shaft shown below **SOLD SEPERATELY (# 8050490)** between the rack and pinion and the steering column, to determine the exact size. If you have a big block, you will need a 3-joint kit.

Small Block Kit

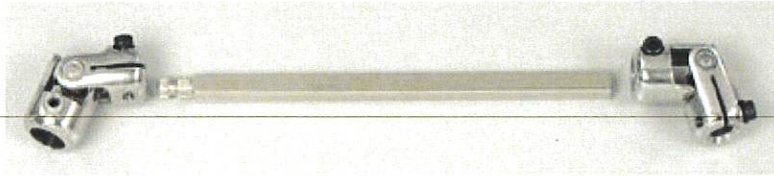

Big Block Kit

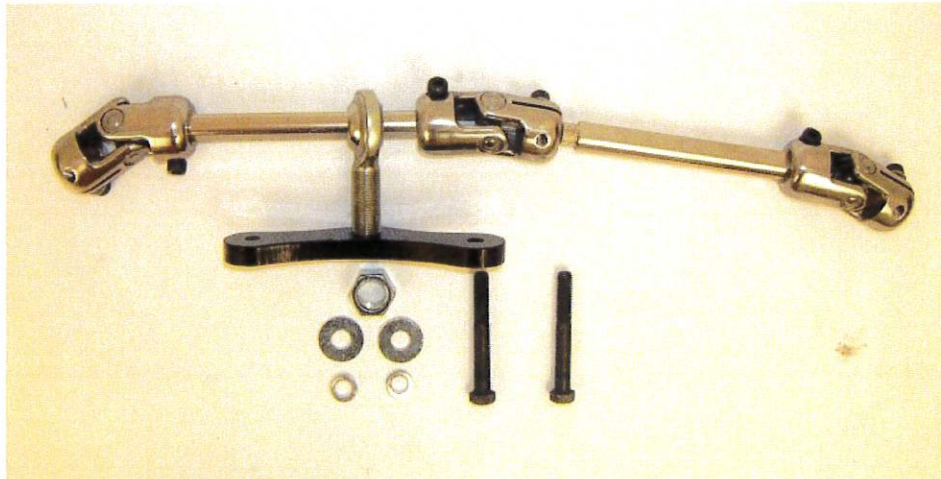

- 4) Trim the steering shaft to size. Be sure to Mis-Phase the steering U-Joints (see illustration on next page). Drill through the u-joint yoke and shaft with the 1/4-inch drill provided. Pin the u-joint to the shaft, using the large pin, and finish by driving the small pin into the large pin. Install the u-joints on the column and the steering gear. Be sure to dimple the column shaft. Tighten fasteners.

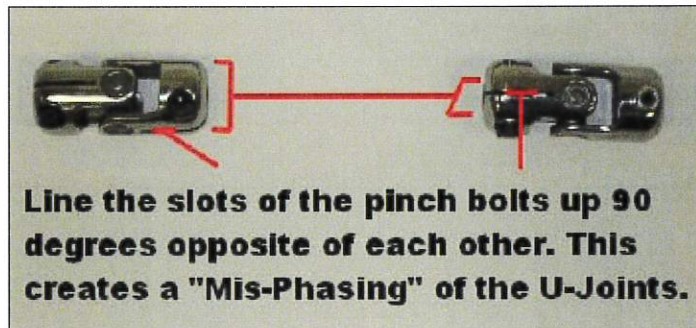

**Note: When installing this kit in a car with a big block, you are limited to specific shaped headers. We used Patriot H8012. It will also be necessary to use 3 steering u-joint when installing this kit with a big block.**

## Pump Installation

The rack & pinion has #6 AN fittings included. The larger port is the pressure and the smaller is the return. Torque these fittings to 20 ft/lbs.

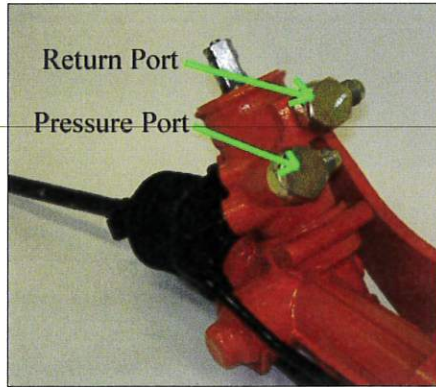

If you are using the new "GEN II" style pump, please be sure to closely follow the accompanied pump installation instructions. Use **ONLY** power steering fluid in this pump and add the fluid to the pump slowly. The rack must be rotated slowly as you add the fluid.

### Alignment Specs:

Toe: 1/16 to 1/8 inch in  
Camber: ¼ degree positive  
Caster: 1.5 – 2 degrees positive

**UNISTEER** *Performance Products*

**1555 Enterprise Parkway  
Twinsburg OH 44087  
800-338-9080**

**[WWW.UNISTEER.COM](http://WWW.UNISTEER.COM)**

Copyright © by MAVAL Manufacturing Corporation All rights reserved.

No part of these materials can be reproduced or utilized in any form or by any means, electronic or mechanical, including photocopying, recording or by any information storage and retrieval system, without permission in writing from MAVAL Manufacturing Corporation.